

Habasit® Cleandrive positive drive CD.P50-A-MC



Main industry segments

Bread, Candy, Chocolate, Dairy (incl. cheese), Frozen food, Fruit, Pizza, Poultry, Ready meals, Red meat, Seafood, Vegetables

Applications

Food processing/conveying belt

Special features

Abrasion resistant on both sides, Bi-directional suitable, Detectable by metal detectors, X-Ray detectable

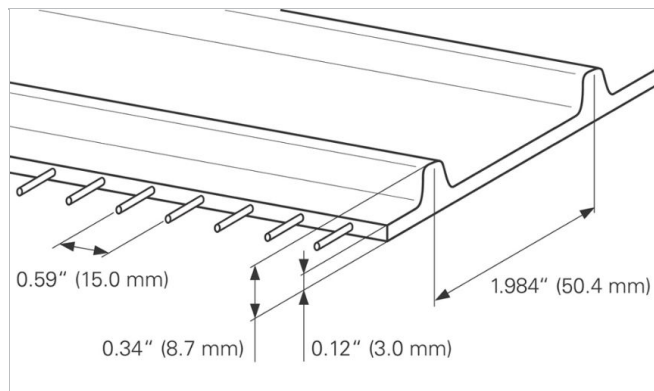
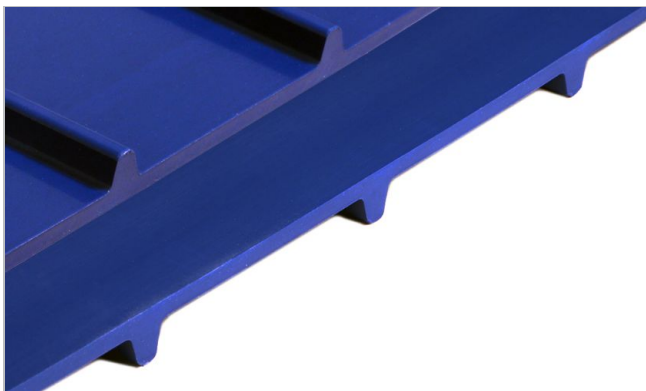

Product Construction / Design	
Material	Thermoplastic polyurethane (TPU)
Color	Cobalt blue
Conveying side surface	Glossy
Conveying side property	Adhesive
Traction layer (material)	Aramid cords
Pulley side surface	Drive bars

Product characteristics	
Antistatically equipped	No
Conveying side conductive surface acc. EN ISO	No
Slider bed suitable	Yes
Carrying rollers suitable	No
UV-C suitable	No
Laser markable	No
Flammability	No specific flammability prevention property
Food suitability, EU conformance	Yes - acc. to Regulation (EC) No. 1935/2004 as well as Regulation (EU) No. 10/2011 and/or other relevant food contact legislation. Details/restrictions see Habasit food compliance declaration.
Food suitability, FDA conformance	Yes - Check Document of Compliance (DoC) in our Portal
Other conformance/approval	Halal certified

Technical data			
Hardness	95	ShA	
Thickness of belt	3.0	mm	0.12 inch
Distance between cords	15	mm	0.59 inch
Nominal drive bar pitch	50.4	mm	1.984 inch
Mass of belt (belt weight)	4.6	kg/m ²	0.942 lb/sqft
Min. operating temperature admissible (continuous)	-20	°C	-4 °F
Max. operating temperature admissible (continuous)	80	°C	176 °F
Coefficient of friction (PE sliding support)	0.40	-	
Minimal width of belt	150	mm	6 inch
Seamless manufacturing width	609	mm	23.98 inch

Joining related properties

Joining method	
Quickmelt	Master joining method for standard applications
Mechanical Lace (SS Rod)	Optional joining method
Mechanical Lace (POM Rod)	Optional joining method

[Link to JDS:](#)

Joining method		Quickmelt	Mechanical Lace (SS Rod)	Mechanical Lace (POM Rod)
Minimal pitch diameter for driving sprockets	mm inch	80.8 3.18	80.8 3.18	80.8 3.18
Minimal pitch diameter for idling sprockets	mm inch	80.8 3.18	80.8 3.18	80.8 3.18
Minimal back-bending roller diameter for center drive configuration	mm inch	100 4	100 4	100 4
Minimal diameter for belt support roller	mm inch	75 3	75 3	75 3
Admissible tensile force per unit of width	N/mm lbf/in	6.0 34	5.5 31	4.0 23
Troughed installation suitable		Yes	No	No
X-Ray / Metal detectable material		Yes	No	No
X-Ray / Metal detector suitable		No	No	No

All data are approximate values under standard climatic conditions: 23°C/73°F, 50% relative humidity (DIN 50005/ISO 554). Limited representative testing based on a standard configuration is carried out to estimate minimum pulley diameters. Please contact Habasit for specific guidance regarding non-standard applications, including, but not exclusively, when profiles or cleats are used, or if the belt working temperature is close to the limits listed in this document.

Chemical resistance

Link to 'Chemical resistance information': <https://rims.habasit.com>

Calculations

Please ask your local Habasit partner to calculate your needs for you and receive the best advise specially suited for your application.

Recommendation

See Engineering Manual

Store spare belts in a cool and dry place and if possible in their original packaging. Protect spare belts from sunlight/UV-radiation/dust/dirt! Check Link for Storage requirements:

["https://tdm.habasit.com/pds/en-us/Storage%20of%20Habasit%20material.pdf"](https://tdm.habasit.com/pds/en-us/Storage%20of%20Habasit%20material.pdf)

This product has not been tested according to ATEX standards (atmospheres with explosion risk - ATEX 95 regulation or EU directive 2014/34/EU) and therefore is subject to user's analysis in the respective environment

Accessories



Sprockets
Habasit® Cleandrive series

Profiles
Longitudinal and transversal profiles

Group	Habasit Cleandrive Positive Drive
Sub-Group	Habasit® Cleandrive Belt Series CD50
Item number	H950021361

Disclaimer

Product Application Disclaimer (valid for ALL Habasit products and mentioned on all PDS)

This disclaimer is made by and on behalf of Habasit and its affiliated companies, directors, employees, agents and contractors (hereinafter collectively "HABASIT") with respect to the products referred to herein (the "Products"). SAFETY WARNINGS SHOULD BE READ CAREFULLY AND ANY RECOMMENDED SAFETY PRECAUTIONS BE FOLLOWED STRICTLY! Please refer to the Safety Warnings herein, in the Habasit catalogue as well as installation and operating manuals. All indications / information as to the application, use and performance of the Products are recommendations provided with due diligence and care, but no representations or warranties of any kind are made as to their completeness, accuracy or suitability for a particular purpose. The data provided herein are based on laboratory application with small-scale test equipment, running at standard conditions, and do not necessarily match product performance in industrial use. New knowledge and experience may lead to re-assessments and modifications within a short period of time and without prior notice. EXCEPT AS EXPLICITLY WARRANTED BY HABASIT, WHICH WARRANTIES ARE EXCLUSIVE AND IN LIEU OF ALL OTHER WARRANTIES, EXPRESS OR IMPLIED, THE PRODUCTS ARE PROVIDED "AS IS". HABASIT DISCLAIMS ALL OTHER WARRANTIES, EITHER EXPRESS OR IMPLIED, INCLUDING, BUT NOT LIMITED TO, IMPLIED WARRANTIES OF MERCHANTABILITY, FITNESS FOR A PARTICULAR PURPOSE, NON-INFRINGEMENT, OR ARISING FROM A COURSE OF DEALING, USAGE, OR TRADE PRACTICE, ALL OF WHICH ARE HEREBY EXCLUDED TO THE EXTENT ALLOWED BY APPLICABLE LAW. BECAUSE CONDITIONS OF USE IN INDUSTRIAL APPLICATION ARE OUTSIDE OF HABASIT'S CONTROL, HABASIT DOES NOT ASSUME ANY LIABILITY CONCERNING THE SUITABILITY AND PROCESS ABILITY OF THE PRODUCTS, INCLUDING INDICATIONS ON PROCESS RESULTS AND OUTPUT.