

HabasitLINK[®] sprockets – 2" pitch belting FF620, FF620 WR, FF620 MC

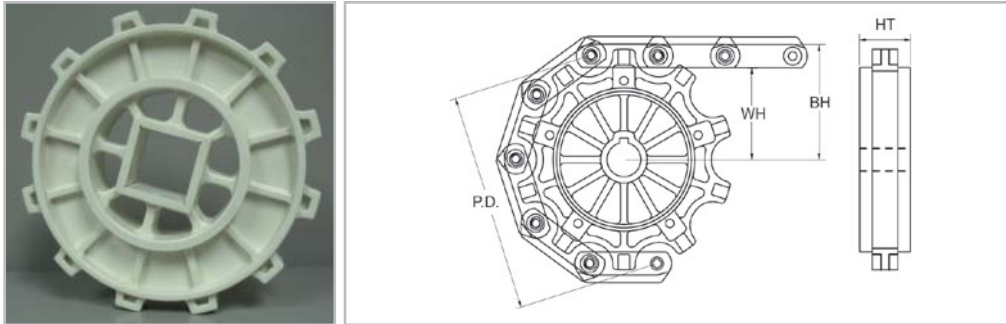

Molded sprocket

Sprocket part number	Number of teeth	(PD) Nominal pitch diameter		(WH) Shaft center to top of wearstrip		Fluid Flo Flat (BH) Shaft center to top of belt		Fluid Flo with Ribs (BH) Shaft center to top of belt raised		Fluid-Flo Mini-Cleat (BH) Shaft center to top of belt cleat		(HT) Hub thickness	
		inch	mm	inch	mm	inch	mm	inch	mm	inch	mm	inch	mm
76206	6	4.00	102	1.46	37	2.14	54	2.36	60	2.36	60	1.5	38
76208M	8	5.23	133	2.08	53	2.76	70	2.98	76	2.98	76	1.5	38
76210M	10	6.47	164	2.70	68	3.38	86	3.6	91	3.6	91	1.5	38
76212M	12	7.73	196	3.33	84	4.01	102	4.23	107	4.23	107	1.5	38
76216	16	10.25	260	4.59	116	5.27	134	5.49	139	5.49	139	1.5	38

M = molded sprocket

Split sprockets and other tooth sizes are available. Standard machined sprocket material is UHMW, Nylon and Urethane are available.

Sprocket part number	Available bore size															
	1"	1" sq.	30 mm	1-1/4"	1-7/16"	1-1/2"	1-1/2" sq.	40 mm	40 mm sq.	1-15/16"	50 mm	2"	60 mm	60 mm sq.	2-1/2" sq.	
76206	✓	✓	✓	✓	✓	✓	✓	✓	✓	–	–	–	–	–	–	
76208M	✓	–	✓	✓	✓	✓	✓	–	✓	–	–	–	–	–	–	
76210M	✓	–	–	–	✓	✓	✓	–	✓	–	–	–	–	–	–	
76212M	–	–	–	–	✓	✓	✓	–	✓	✓	–	✓	–	–	✓	
76216	✓	✓	✓	✓	✓	✓	✓	✓	✓	✓	✓	✓	✓	✓	✓	

M = molded sprocket

All bore sizes are round bore unless designated square (sq.).