

HabasitLINK[®] sprockets – 1" pitch belting

MB610, MB610 MTW

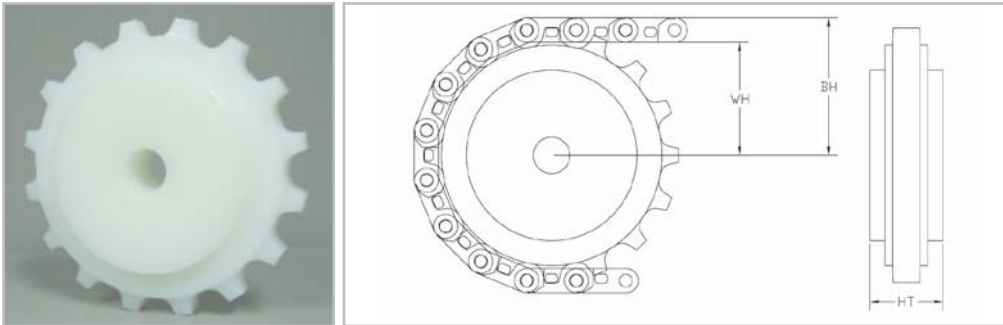

Machined sprocket

Sprocket part number	Number of teeth	(PD) Nominal pitch diameter		(WH) Shaft center to top of wearstrip		(BH) Shaft center to top of belt		(HT) Hub thickness	
		inch	mm	inch	mm	inch	mm	inch	mm
MB71012	12	3.86	98	1.68	43	2.18	55	1.5	38
MB71016	16	5.12	130	2.31	59	2.81	71	1.5	38
MB71018	18	5.76	146	2.63	67	3.13	80	1.5	38
MB71021	21	6.71	170	3.10	79	3.60	91	1.5	38
MB71031	31	9.89	251	4.69	119	5.19	132	1.5	38

Split sprockets and other tooth sizes are available. Standard machined sprocket material is UHMW, Nylon and Urethane are available.

Sprocket part number	Available bore size															
	25 mm	1"	1" sq.	30 mm	1-1/4"	1-7/16"	1-1/2"	1-1/2" sq.	40 mm	40 mm sq.	1-15/16"	50 mm	2" sq.	60 mm	60 mm sq.	2-1/2" sq.
MB71012	✓	✓	✓	✓	✓	✓	✓	✓	✓	✓	✓	–	–	–	–	–
MB71016	✓	✓	✓	✓	✓	✓	✓	✓	✓	✓	✓	✓	–	–	–	–
MB71018	✓	✓	✓	✓	✓	✓	✓	✓	✓	✓	✓	✓	–	–	–	–
MB71021	✓	✓	✓	✓	✓	✓	✓	✓	✓	✓	✓	✓	✓	–	–	–
MB71031	✓	✓	✓	✓	✓	✓	✓	✓	✓	✓	✓	✓	✓	✓	✓	✓

All bore sizes are round bore unless designated square (sq.).