

HabasitLINK® sprockets – 2" pitch belting

PR620, PR620 SPS, PR620 TTR

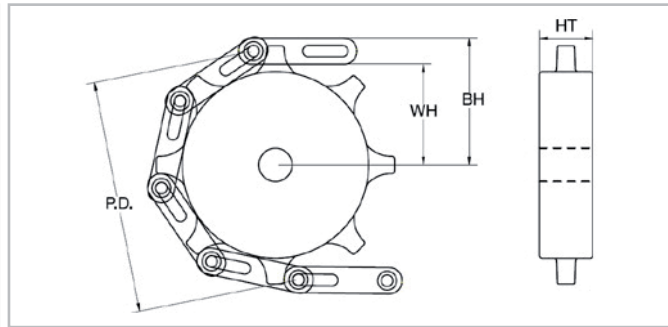

Machined sprocket – PR620

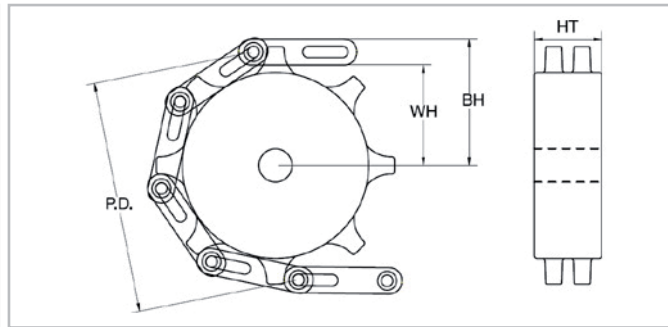

Machined sprocket – PR620 SPS

Sprocket part number	Number of teeth	(PD) Nominal pitch diameter		(WH) Shaft center to top of wearstrip		(BH) Shaft center to top of belt		(HT) Hub thickness	
		inch	mm	inch	mm	inch	mm	inch	mm
PR72010	10	6.5	165	2.9	74	3.5	89	1.25	32
PR72010 SPS	10	6.5	165	2.9	74	3.5	89	1.25	32

Split sprockets and other tooth sizes are available. Standard machined sprocket material is UHMW. Nylon and Urethane are available. PR620 TTR belts use a combination of PR620 and PR620 SPS sprockets.

Sprocket part number	Available bore size															
	25 mm	1"	1" sq.	30 mm	1-1/4"	1-7/16"	1-1/2"	1-1/2" sq.	40 mm	40 mm sq.	1-15/16"	50 mm	2" sq.	60 mm	60 mm sq.	2-1/2" sq.
PR72010	✓	✓	✓	✓	✓	✓	✓	✓	✓	✓	✓	✓	✓	✓	–	–
PR72010 SPS	✓	✓	✓	✓	✓	✓	✓	✓	✓	✓	✓	✓	✓	✓	–	–

All bore sizes are round bore unless designated square (sq.).