

HabaSYNC Open-end Timing Belts HGA-A

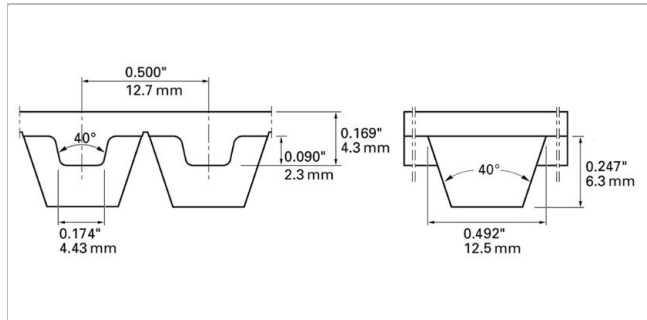

Description

0.5" pitch, Imperial, T shape, Standard trapezoidal, Aramid cord, Self-tracking

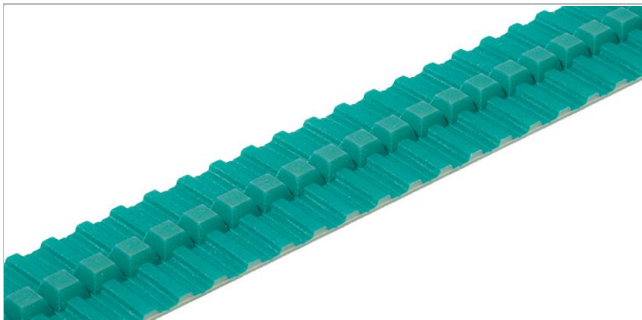

Sketch of basic shape

Product Construction / Design

Material Type	Color	Hardness	Temperature range				Food grade ¹	Characteristic
			°C	°F	°C	°F		
02	Transparent	88	-20	-4	70	158	Yes	TPU - polyester

⁽¹⁾ This product is in compliance with relevant EU and/or US food contact requirements. Check the following link for detailed information [Documents of Compliance](#)

Standard belt options - Conveying side

Unprocessed (U), Green polyamide fabric (P)

Standard belt options - Teeth side

Unprocessed (U), Green polyamide fabric (P)

Technical data

Belt slitting width, nominal		Admissible tensile force, open belt		Admissible tensile force, joined belt		Tensile force for 1% elongation		Mass of belt (belt weight)	
mm	inch	N	lbf	N	lbf	N	lbf	kg/m	lb/ft
25.4	1.00	2000	450	1000	225	3333	749	0.10	0.07

Maximum belt width (150 mm / 6 inch).

Belt versions with increased thickness are available on request. Please consider larger minimum pulley diameters.

The ultimate tensile strength (or breaking strength) for the widest slitting width mentioned above is 15400 N.

The admissible tensile force always corresponds with a belt elongation of 0.6%. Joined belts are calculated with half admissible force. Please contact Habasit for detailed information and calculations.

[Link to JDS:](#)

Technical data

ØB		n _B	ØA		n _A
mm	inch		mm	inch	
60	2.36	14	80	3.15	20

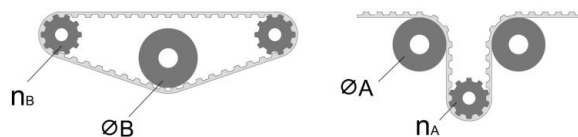

All data are approximate values under **standard climatic conditions**: 23 °C / 73 °F, 50% relative humidity (DIN 50005 / ISO 554), and are based on the Master Joining Method.

Limited representative testing based on a standard configuration is carried out to estimate minimum pulley diameters. Please contact Habasit for specific guidance regarding non-standard applications, including, but not exclusively, when profiles or cleats are used, or if the belt working temperature is close to the limits listed in this document.

HabaSYNC Open-end Timing Belts HGA-A



Disclaimer

Product Application Disclaimer (valid for ALL Habasit products and mentioned on all PDS)

This disclaimer is made by and on behalf of Habasit and its affiliated companies, directors, employees, agents and contractors (hereinafter collectively "HABASIT") with respect to the products referred to herein (the "Products"). SAFETY WARNINGS SHOULD BE READ CAREFULLY AND ANY RECOMMENDED SAFETY PRECAUTIONS BE FOLLOWED STRICTLY! Please refer to the Safety Warnings herein, in the Habasit catalogue as well as installation and operating manuals. All indications / information as to the application, use and performance of the Products are recommendations provided with due diligence and care, but no representations or warranties of any kind are made as to their completeness, accuracy or suitability for a particular purpose. The data provided herein are based on laboratory application with small-scale test equipment, running at standard conditions, and do not necessarily match product performance in industrial use. New knowledge and experience may lead to re-assessments and modifications within a short period of time and without prior notice.

EXCEPT AS EXPLICITLY WARRANTED BY HABASIT, WHICH WARRANTIES ARE EXCLUSIVE AND IN LIEU OF ALL OTHER WARRANTIES, EXPRESS OR IMPLIED, THE PRODUCTS ARE PROVIDED "AS IS". HABASIT DISCLAIMS ALL OTHER WARRANTIES, EITHER EXPRESS OR IMPLIED, INCLUDING, BUT NOT LIMITED TO, IMPLIED WARRANTIES OF MERCHANTABILITY, FITNESS FOR A PARTICULAR PURPOSE, NON-INFRINGEMENT, OR ARISING FROM A COURSE OF DEALING, USAGE, OR TRADE PRACTICE, ALL OF WHICH ARE HEREBY EXCLUDED TO THE EXTENT ALLOWED BY APPLICABLE LAW. BECAUSE CONDITIONS OF USE IN INDUSTRIAL APPLICATION ARE OUTSIDE OF HABASIT'S CONTROL, HABASIT DOES NOT ASSUME ANY LIABILITY CONCERNING THE SUITABILITY AND PROCESS ABILITY OF THE PRODUCTS, INCLUDING INDICATIONS ON PROCESS RESULTS AND OUTPUT.