

Habasit® Cleandrive positive drive CD.P25-A-UC



Main industry segments

Bread, Candy, Chocolate, Dairy (incl. cheese), Frozen food, Fruit, Pizza, Poultry, Ready meals, Red meat, Seafood, Vegetables

Applications

Food processing/conveying belt

Special features

Abrasion resistant on both sides, Bi-directional suitable, Easy cleanability

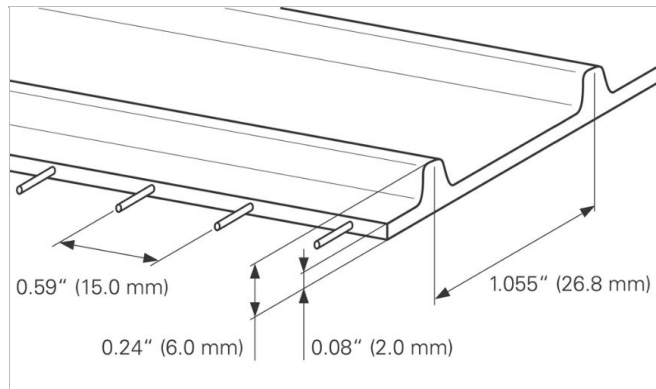
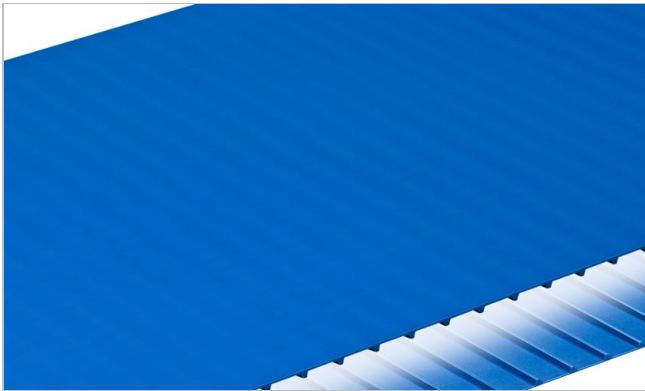

Product Construction / Design	
Material	Thermoplastic polyurethane (TPU)
Cor	Cobalt blue
Conveying side surface	Glossy
Conveying side property	Adhesive
Traction layer (material)	Aramid cords
Pulley side surface	Drive bars

Product characteristics	
Antistatically equipped	No
Conveying side conductive surface acc. EN ISO	No
Slider bed suitable	Yes
Carrying rollers suitable	No
UV-C suitable	No
Laser markable	No
Flammability	No specific flammability prevention property
Food suitability, EU conformance	Yes - acc. to Regulation (EC) No. 1935/2004 as well as Regulation (EU) No. 10/2011 and/or other relevant food contact legislation. Details/restrictions see Habasit food compliance declaration.
Food suitability, FDA conformance	Yes - Check Document of Compliance (DoC) in our Portal
Food suitability, USDA recommendations	USDA certified for compliance with USDA Dairy Equipment Guidelines and NSF/ANSI/3-A 14159-3 standard for Meat and Poultry Processing. Certification is valid only if belt edges are sealed or belt cords are not exposed and when optional belt accessories like cleats, v-guides and scoops comply with the applicable FDA regulations for the conveyed product. Contact your Habasit representative for detailed information.
Other conformance/approval	Halal certified, Japanese Food Regulation (MHLW Notification No. 370), Rice grain elevators

Technical data			
Hardness	95	ShA	
Thickness of belt	2.0	mm	0.08 inch
Distance between cords	15	mm	0.59 inch
Nominal drive bar pitch	26.8	mm	1.055 inch
Mass of belt (belt weight)	3.1	kg/m ²	0.635 lb/sqft
Min. operating temperature admissible (continuous)	-20	°C	-4 °F
Max. operating temperature admissible (continuous)	80	°C	176 °F
Coefficient of friction (pulley side / PE wearstrips)	0.50	-	
Coefficient of friction (pulley side / stainless steel slider bed)	0.80	-	
Coefficient of friction (conveying side / PE wearstrips)	0.50	-	
Minimal width of belt	150	mm	6 inch
Seamless manufacturing width	1829	mm	72.01 inch

Joining related properties

Joining method	
Quickmelt	Master joining method for standard applications
Mechanical Lace (SS Rod)	Optional joining method
Mechanical Lace (POM Rod)	Optional joining method

[Link to JDS:](#)

Joining method		Quickmelt	Mechanical Lace (SS Rod)	Mechanical Lace (POM Rod)
Minimal pitch diameter for driving sprockets	mm inch	60.1 2.37	60.1 2.37	60.1 2.37
Minimal pitch diameter for idling sprockets	mm inch	43.0 1.69	43.0 1.69	43.0 1.69
Minimal back-bending roller diameter for center drive configuration	mm inch	75 3	75 3	75 3
Minimal diameter for belt support roller	mm inch	50 2	50 2	50 2
Admissible tensile force per unit of width	N/mm lbf/in	6.0 34	3.0 17	1.8 10
Troughed installation suitable		Yes	No	No
X-Ray / Metal detectable material		No	No	No
X-Ray / Metal detector suitable		Yes	No	Yes

All data are approximate values under standard climatic conditions: 23°C/73°F, 50% relative humidity (DIN 50005/ISO 554). Limited representative testing based on a standard configuration is carried out to estimate minimum pulley diameters. Please contact Habasit for specific guidance regarding non-standard applications, including, but not exclusively, when profiles or cleats are used, or if the belt working temperature is close to the limits listed in this document.

Chemical resistance

Link to 'Chemical resistance information': <https://rims.habasit.com>

Calculations

Please ask your local Habasit partner to calculate your needs for you and receive the best advise specially suited for your application.

Recommendation

See Engineering Manual

Store spare belts in a cool and dry place and if possible in their original packaging. Protect spare belts from sunlight/UV-radiation/dust/dirt! Check Link for Storage requirements:

["https://tdm.habasisit.com/pds/en-us/Storage%20of%20Habasisit%20material.pdf"](https://tdm.habasisit.com/pds/en-us/Storage%20of%20Habasisit%20material.pdf)

This product has not been tested according to ATEX standards (atmospheres with explosion risk - ATEX 95 regulation or EU directive 2014/34/EU) and therefore is subject to user's analysis in the respective environment

Accessories



Sprockets

Habasisit® Cleandrive series

Sprockets

Habasisit® Cleandrive HyCLEAN series

Profiles

Longitudinal and transversal profiles

Group

Habasisit Cleandrive Positive Drive

Sub-Group

Habasisit® Cleandrive Belt Series CD25

Número de item

H010102853

Esta renúncia é efetuada em nome da Habasisit e das suas empresas filiais, diretores, funcionários, agentes e prestadores (adiante coletivamente "HABASIT") no que respeita aos produtos referidos no presente (os "Produtos"). OS AVISOS DE SEGURANÇA DEVEM SER LIDOS CUIDADOSAMENTE E QUAISQUER PRECAUÇÕES DE SEGURANÇA RECOMENDADAS DEVEM SER ESTRITAMENTE SEGUIDAS! Consulte os Avisos de segurança do presente, no catálogo da Habasisit, bem como nos manuais de instalação e funcionamento. Todas as indicações/informações relativas à aplicação, utilização e desempenho dos Produtos são recomendações fornecidas com a devida diligência e cuidado, mas não é efetuada qualquer representação ou garantia de qualquer tipo quanto à respetiva integralidade, precisão ou adequação a um fim em particular. Os dados fornecidos no presente são baseados na aplicação de laboratório com equipamento de teste de pequena escala, a funcionar em condições padrão e não correspondem necessariamente ao desempenho do produto em utilização industrial. Novos conhecimentos e experiência poderão levar a reavaliações e modificações num curto espaço de tempo e sem aviso prévio. EXCETO CONFORME EXPLICITAMENTE GARANTIDO PELA HABASIT, CUJAS GARANTIAS SÃO EXCLUSIVAS E SUBSTITUEM TODAS AS OUTRAS GARANTIAS, EXPRESSAS OU IMPLÍCITAS, OS PRODUTOS SÃO FORNECIDOS "TAL QUAL". A HABASIT RENUNCIA A QUAISQUER OUTRAS GARANTIAS, QUER EXPRESSAS OU IMPLÍCITAS, INCLUINDO, MAS NÃO LIMITADO A, GARANTIAS DE COMERCIALIZAÇÃO, ADEQUAÇÃO A UM FIM PARTICULAR, NÃO INFRAÇÃO OU DECORRENTES DE UM CURSO DE NEGOCIAÇÃO, UTILIZAÇÃO OU PRÁTICA DE NEGOCIAÇÃO, TODAS AS QUAIS SÃO PELO PRESENTE EXCLUÍDAS, NA MEDIDA DO PERMITIDO PELA LEI APLICÁVEL. DADO AS CONDIÇÕES DE UTILIZAÇÃO NA APLICAÇÃO INDUSTRIAL ESTAREM FORA DO CONTROLO DA HABASIT, A MESMA NÃO ASSUME QUALQUER RESPONSABILIDADE RELATIVAMENTE À ADEQUAÇÃO E CAPACIDADE