

Extended pivots and inserts can be fitted to the multiflex range of chains. Inserts are beneficial for incline or decline applications where the extended pivots can be used for a variety of applications where the product is required to be spaced, held or pushed where the stand alone chain is not sufficient. Both inserts and extended pivots are available in standard arrangements as well as to customer requirements.

Extended pivot

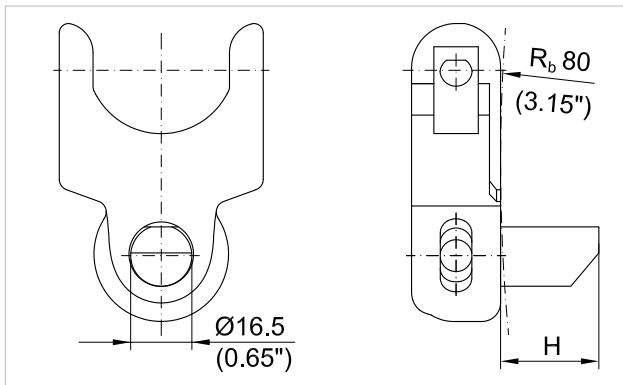

Insert

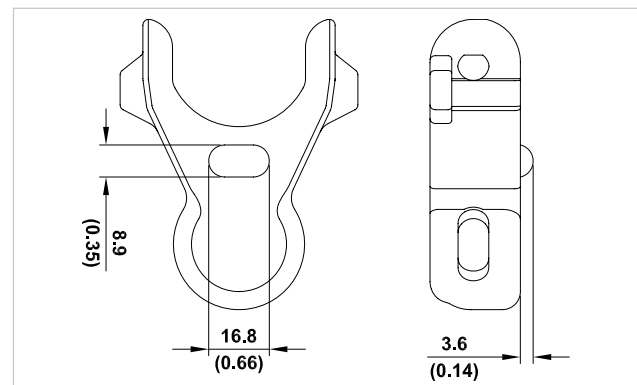

Standard accessories

Chain type	Accessory type	Dimension H		Standard material
		mm	inch	
C1700	Extended pivot	26.5	1.04	PA white
C1701T C1702		25.5	1.00	
C1700 C1701T C1702	Insert	-	-	see material overview

Custom dimensions and arrangements available by request.

Turn disc are available for the Multiflex range of chains. Turn discs are used as moving inside wearstrips for turns. By using the turn disc, the chain can go through a curve without significantly increasing the chain tension, consequently, allowing longer conveyors. It is recommended to utilize turn disc for multiflex chains.

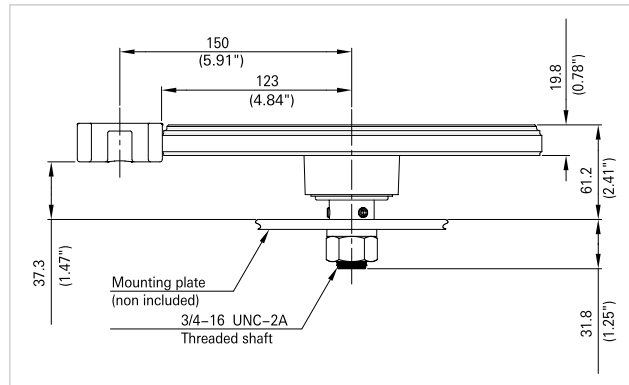

Turn disc type	Chain type	Center of disc to center of chain		Weight	
		mm	inch	kg	lbs
C1700D12	C1700K0217--AA	150	5.91	1.39	3.05

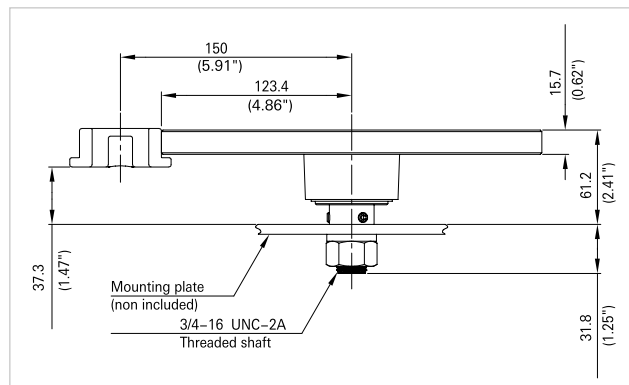

Turn disc type	Chain type	Center of disc to center of chain		Weight	
		mm	inch	kg	lbs
C1701D12	C1701K0209--TA	150	5.91	1.32	2.90
	C1702K0209--AA	150	5.91	1.32	2.90

Material:

- Disc: Cast aluminum
- Shaft: Stainless steel