

HabasitLINK[®]

Installation instructions for belt types FF620, FF620MC, FF620WR

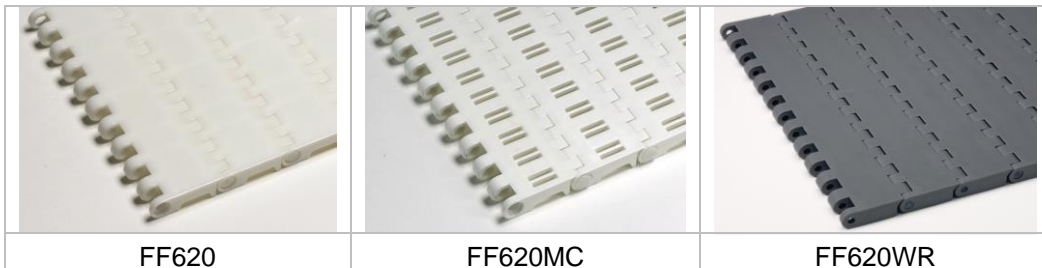

⚠ CAUTION: Acetal belts will burn with a flame that is nearly invisible

Preferred running direction and position of sprockets:

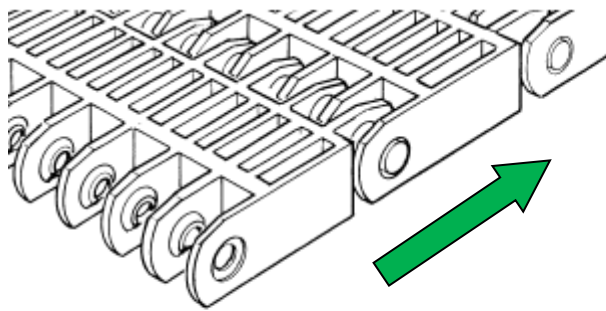

Belts are bidirectional

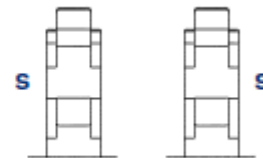
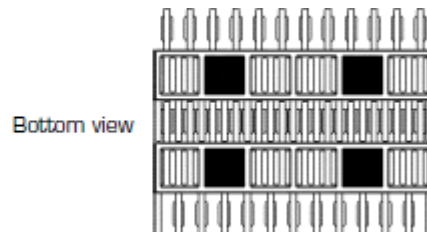

Maximum distance between sprockets is 6" (152mm)

Belt assembly:

| Belt width ≤ 50" (1270 mm) | Belt width > 50" (1270 mm) and ≤ 98" (2490 mm) | Belt width > 98" (2490 mm) |
|--------------------------------------------------------------------------------------------------------------------------------------|--------------------------------------------------------------------------------------------------------------------------------------|--------------------------------------------------------------------------------------------------------------------------------------|
| Align the modules to be connected | Align the modules to be connected | Align the modules to be connected |
| Insert the new rod | Cut rods between ¼" to ½" shorter than the width of the belt, cutting one short one and one long one | Cut rods and/or floaters to the right belt width, leave ¼" to ½" between these for expansion. Cut a long and a short rod |
| Use a small plastic tipped hammer to tap the rod while supporting the outer knuckle until the head of the rod is flush with the belt | Insert rods from both sides, alternating short and long rod every pitch | Insert rod from one side and the floater and rod from the other side alternating short and long rod every pitch |
| Trim off excess rod opposite head flush with the side of the belt | Use a small plastic tipped hammer to tap the rod while supporting the outer knuckle until the head of the rod is flush with the belt | Use a small plastic tipped hammer to tap the rod while supporting the outer knuckle until the head of the rod is flush with the belt |

Belt disassembly:



Insert clippers between the first and second finger of the belt on the headed side of the rod. [Bending the belt at the hinge will make it easier to insert the clippers, if bending is possible.]



Pry out the head of the rod with the clippers. The rod can then be easily removed by hand.

Replace all removed rods as they will be damaged during disassembly.

Disclaimer

Product Application Disclaimer (valid for ALL Habasit products and mentioned on all PDS)

This disclaimer is made by and on behalf of Habasit and its affiliated companies, directors, employees, agents and contractors (hereinafter collectively "HABASIT") with respect to the products referred to herein (the "Products"). SAFETY WARNINGS SHOULD BE READ CAREFULLY AND ANY RECOMMENDED SAFETY PRECAUTIONS BE FOLLOWED STRICTLY! Please refer to the Safety Warnings herein, in the Habasit catalogue as well as installation and operating manuals. All indications / information as to the application, use and performance of the Products are recommendations provided with due diligence and are, but no representations or warranties of any kind are made as to their completeness, accuracy or suitability for a particular purpose. The data provided herein are based on laboratory application with small-scale test equipment, running at standard conditions, and do not necessarily match product performance in industrial use. New knowledge and experience may lead to re-assessments and modifications within a short period of time and without prior notice. EXCEPT AS EXPLICITLY WARRANTED BY HABASIT, WHICH WARRANTIES ARE EXCLUSIVE AND IN LIEU OF ALL OTHER WARRANTIES, EXPRESS OR IMPLIED, THE PRODUCTS ARE PROVIDED "AS IS". HABASIT DISCLAIMS ALL OTHER WARRANTIES, EITHER EXPRESS OR IMPLIED, INCLUDING, BUT NOT LIMITED TO, IMPLIED WARRANTIES OF MERCHANTABILITY, FITNESS FOR A PARTICULAR PURPOSE, NON-INFRINGEMENT, OR ARISING FROM A COURSE OF DEALING, USAGE, OR TRADE PRACTICE, ALL OF WHICH ARE HEREBY EXCLUDED TO THE EXTENT ALLOWED BY APPLICABLE LAW. BECAUSE CONDITIONS OF USE IN INDUSTRIAL APPLICATION ARE OUTSIDE OF HABASIT'S CONTROL, HABASIT DOES NOT ASSUME ANY LIABILITY CONCERNING THE SUITABILITY AND PROCESS ABILITY OF THE PRODUCTS, INCLUDING INDICATIONS ON PROCESS RESULTS AND OUTPUT.

