

HabasitLINK®

Installation instructions for belt type M2592

Please find full installation guide on www.habasitlink.com

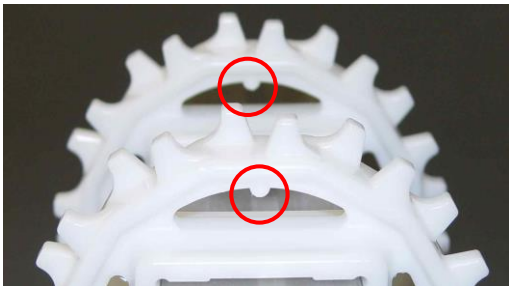

Sprocket alignment on the shafts:

Corresponding teeth axial aligned, check by alignment mark.

If the bore is square and the number of teeth can be divided by 4, there is may be no mark.

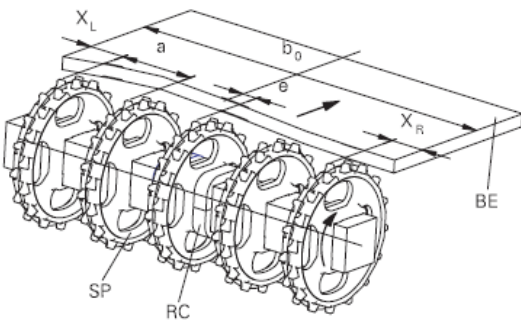

Sprockets Positioning:

Place sprockets between min. and max. spacing (a).

Offset (e) given by shaft design.

Fix only the sprocket in the middle with a small clearance.

Belt type	Sprocket spacing a		Edge distance*	
	minimal mm inch	maximal mm inch	X _L mm inch	X _R mm inch
M2592	50 2	117 4.6	39 1.53	29 1.15

* X_L and X_R are related to running direction A and are inverse for the running direction B

Respect minimal edge distance X_L and X_R depending on running direction.

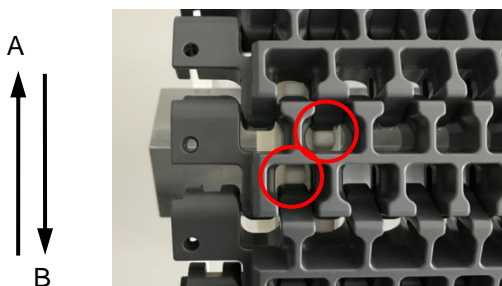

Belt running direction:

This belt can run in both directions but it might be given by the shaft design with fixed sprocket and offset (e). Install the belts whenever possible with rod heads on the outside of the curve.

Preferred running direction for radius and spiral conveyors is A.



Check proper sprocket engagement:

The sprocket teeth must properly engage in the belt.

Belt reverse side is in contact with the sprocket rim.

Check proper sprocket engagement from belt surface.

Rod installation (smart fit rod retention):

Rod Ø5mm (0.2") with octagonal shaped head must have a beveled end. Install the belt with rod head on the outside of the curve. In case of more curves with opposite direction install belt with rod head on outside at last curve (closer to head drive), for wide belts there might be two rods per row (S-curve).



Pull belt sections together

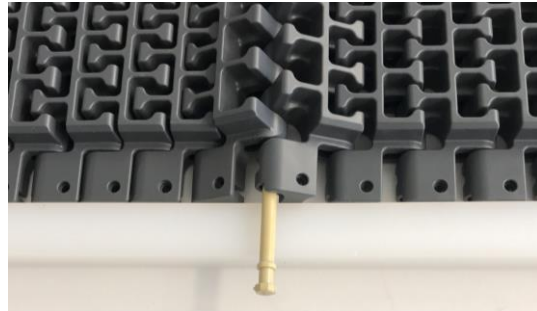

Insert rod

For easy rod installation, rod end must be beveled.

Warning: Do not enter your fingers into holes of belt => There is a risk of injury to fingers



For proper rod installation use a plastic hammer.

Check if rod head is fully embedded.

Rod removing (smart fit rod retention)

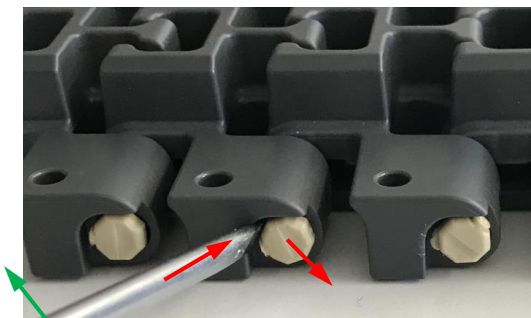

Leverage rod head out

Rod removal by screwdriver.

The belt must not be under tension.

Rod head must be octagonal shaped.

Apply screwdriver at rod head from the left (see arrow).

Do not punch out rod by hammer.

Product liability, application considerations

If the proper selection and application of Habasit products are not recommended by an authorized Habasit sales specialist, the selection and application of Habasit products, including the related area of product safety, are the responsibility of the customer. All indications / information are recommendations and believed to be reliable, but no representations, guarantees, or warranties of any kind are made as to their accuracy or suitability for particular applications. The data provided herein are based on laboratory work with small-scale test equipment, running at standard conditions, and do not necessarily match product performance in industrial use. New knowledge and experiences can lead to modifications and changes within a short time without prior notice.

BECAUSE CONDITIONS OF USE ARE OUTSIDE OF HABASIT'S AND ITS AFFILIATED COMPANIES' CONTROL, WE CANNOT ASSUME ANY LIABILITY CONCERNING THE SUITABILITY AND PROCESS ABILITY OF THE PRODUCTS MENTIONED HEREIN. THIS ALSO APPLIES TO PROCESS RESULTS / OUTPUT / MANUFACTURING GOODS AS WELL AS TO POSSIBLE DEFECTS, DAMAGES, CONSEQUENTIAL DAMAGES, AND FURTHER-REACHING CONSEQUENCES.

