

# HabasitLINK®

## Installation instructions for belt type M5182

Please find full installation guide on [www.habasitlink.com](http://www.habasitlink.com)

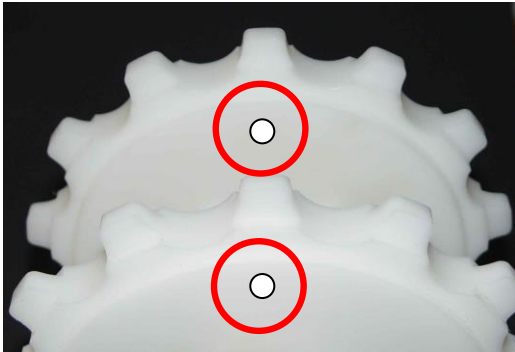

Sprocket alignment on the shafts:

**Corresponding teeth axial aligned, check by alignment mark.**

**If the bore is square and the number of teeth can be divided by 4, there may be no mark.**

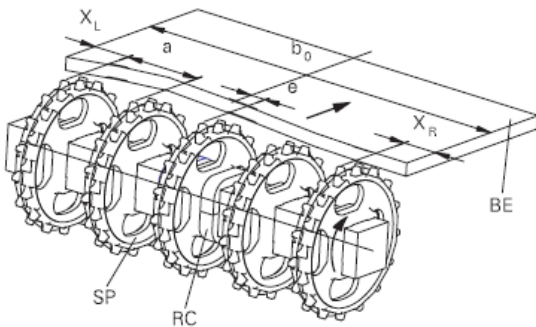

### Sprockets Positioning:

Place sprockets between min. and max. spacing (a).

Respect edge distance  $X_L$  and  $X_R$ .

Offset (e) given by shaft design.

Fix only the sprocket in the middle with small clearance.

Belt type	Sprocket spacing a		Edge distance (minimal)	
	minimal mm inch	maximal mm inch	$X_L$ mm inch	$X_R$ mm inch
M5182	50.8 2	101.6 4	25.4 1	25.4 1



### Check proper sprocket engagement:

The sprocket teeth must properly engage in the belt.

Belt reverse side is in contact with the sprocket rim.

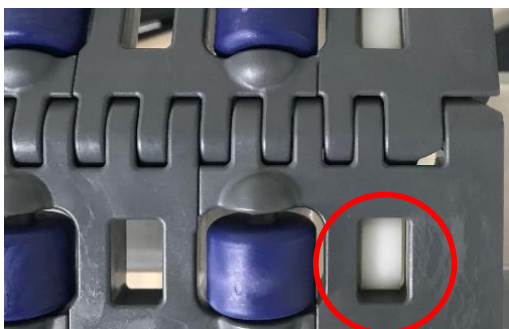

Sprocket teeth are engaging in the module cavities at belt edges and in-between the rollers.

**Rod installation (smart fit rod retention):**

Rod Ø7mm (0.27") with octagonal shaped head must have a beveled end. If the belt is delivered in sections, join the sections with alternating rod head orientation e.g. on one section all rod heads on the left hand side and the following section all rod heads on the right hand side. For wide belts there might be two short headed rods at belt edges and a headless rod floater between them.



Pull belt sections together



Insert rod.  
For easy installation rod end must be beveled.

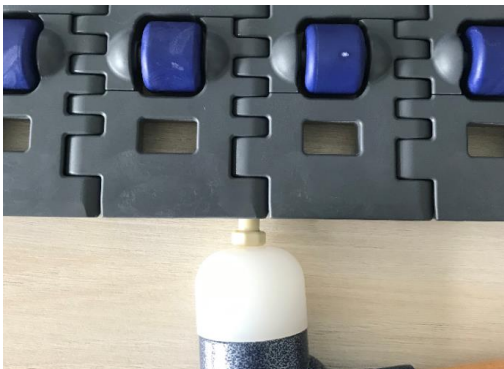

Push in rod head

Check if rod head is fully embedded.

**Rod removal (smart fit rod retention):**

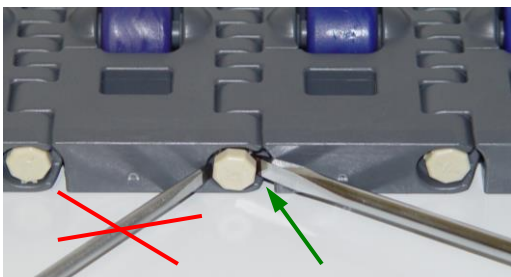

**Rod removal by screwdriver**  
Apply screwdriver at rod head (see arrow).  
Do not punch out rod by hammer.  
The belt must not be under tension.

**Product liability, application considerations**

If the proper selection and application of Habasit products are not recommended by an authorized Habasit sales specialist, the selection and application of Habasit products, including the related area of product safety, are the responsibility of the customer. All indications / information are recommendations and believed to be reliable, but no representations, guarantees, or warranties of any kind are made as to their accuracy or suitability for particular applications. The data provided herein are based on laboratory work with small-scale test equipment, running at standard conditions, and do not necessarily match product performance in industrial use. New knowledge and experiences can lead to modifications and changes within a short time without prior notice.

BECAUSE CONDITIONS OF USE ARE OUTSIDE OF HABASIT'S AND ITS AFFILIATED COMPANIES' CONTROL, WE CANNOT ASSUME ANY LIABILITY CONCERNING THE SUITABILITY AND PROCESS ABILITY OF THE PRODUCTS MENTIONED HEREIN. THIS ALSO APPLIES TO PROCESS RESULTS / OUTPUT / MANUFACTURING GOODS AS WELL AS TO POSSIBLE DEFECTS, DAMAGES, CONSEQUENTIAL DAMAGES, AND FURTHER-REACHING CONSEQUENCES.

