

HabasitLINK®

Installation instructions for belt type PR620 Smart Fit (Spiral Pro)



⚠ CAUTION: Acetal belts will burn with a flame that is nearly invisible

Preferred running direction:

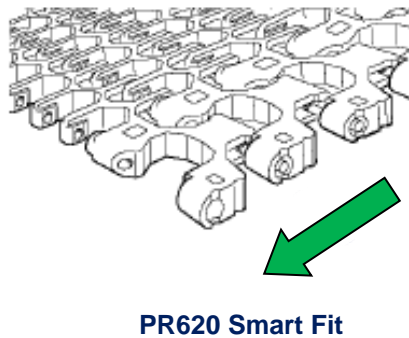

Position of sprockets:

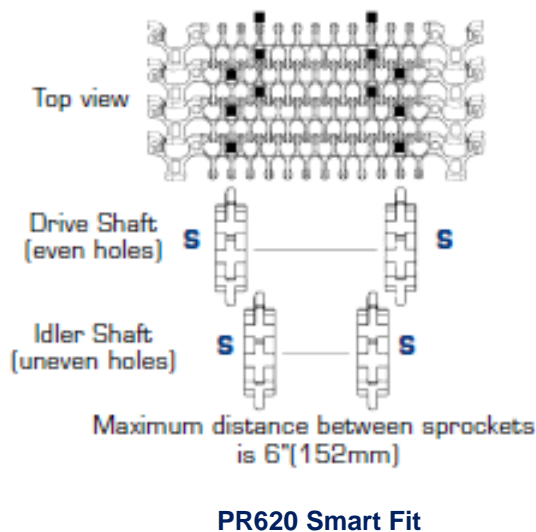

Belt assembly:

Belt width ≤ 24" (610 mm)	Belt width > 24" (610 mm) and ≤ 45" (1143 mm)	Belt width > 45" (1143 mm)
Align the modules to be connected	Align the modules to be connected	Align the modules to be connected
Insert the new Smart Fit rod	Cut Smart Fit rods between ¼" to ½" shorter than the width of the belt, cutting one short one and one long one	Cut Smart Fit rods and/or floaters to the right belt width, leave ¼" to ½" between these for expansion. Cut a long and a short rod
Use a small plastic tipped hammer to tap the Smart Fit rod while supporting the outer knuckle until the head of the rod is flush with the belt	Insert Smart Fit rods from both sides, alternating short and long rod every pitch	Insert Smart Fit rod from one side and the floater and Smart Fit rod from the other side alternating short and long rod every pitch
Trim off excess rod opposite head flush with the side of the belt	Use a small plastic tipped hammer to tap the Smart Fit rods while supporting the outer knuckle until the head of the Smart Fit rod is flush with the belt	Use a small plastic tipped hammer to tap the Smart Fit rod while supporting the outer knuckle until the head of the Smart Fit rod is flush with the belt

Belt disassembly:

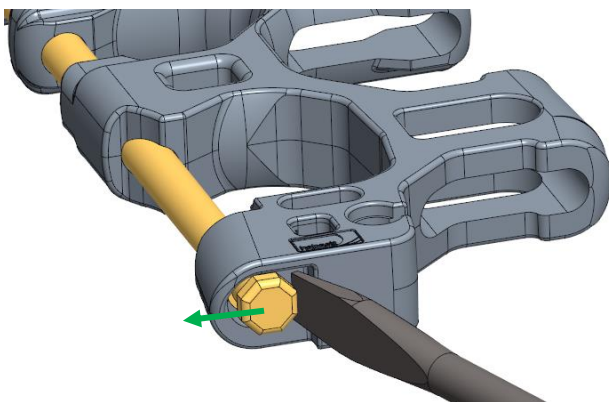

Fig. 1 Rod release with use of screwdriver

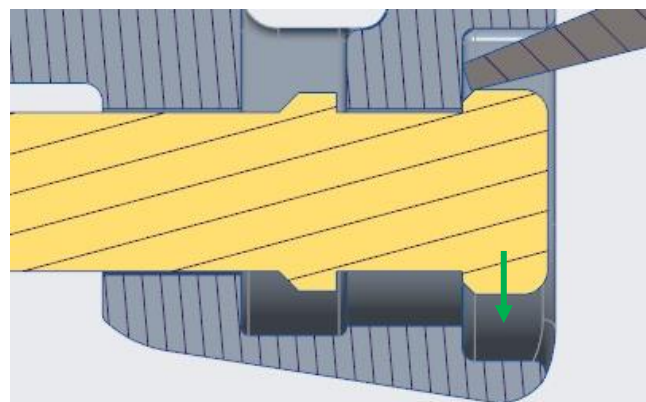

Fig. 2 Cross section of rod retaining system

Disclaimer

Product Application Disclaimer (valid for ALL Habasit products and mentioned on all PDS)

This disclaimer is made by and on behalf of Habasit and its affiliated companies, directors, employees, agents and contractors (hereinafter collectively "HABASIT") with respect to the products referred to herein (the "Products"). SAFETY WARNINGS SHOULD BE READ CAREFULLY AND ANY RECOMMENDED SAFETY PRECAUTIONS BE FOLLOWED STRICTLY! Please refer to the Safety Warnings herein, in the Habasit catalogue as well as installation and operating manuals. All indications / information as to the application, use and performance of the Products are recommendations provided with due diligence and are, but no representations or warranties of any kind are made as to their completeness, accuracy or suitability for a particular purpose. The data provided herein are based on laboratory application with small-scale test equipment, running at standard conditions, and do not necessarily match product performance in industrial use. New knowledge and experience may lead to re-assessments and modifications within a short period of time and without prior notice. EXCEPT AS EXPLICITLY WARRANTED BY HABASIT, WHICH WARRANTIES ARE EXCLUSIVE AND IN LIEU OF ALL OTHER WARRANTIES, EXPRESS OR IMPLIED, THE PRODUCTS ARE PROVIDED "AS IS". HABASIT DISCLAIMS ALL OTHER WARRANTIES, EITHER EXPRESS OR IMPLIED, INCLUDING, BUT NOT LIMITED TO, IMPLIED WARRANTIES OF MERCHANTABILITY, FITNESS FOR A PARTICULAR PURPOSE, NON-INFRINGEMENT, OR ARISING FROM A COURSE OF DEALING, USAGE, OR TRADE PRACTICE, ALL OF WHICH ARE HEREBY EXCLUDED TO THE EXTENT ALLOWED BY APPLICABLE LAW. BECAUSE CONDITIONS OF USE IN INDUSTRIAL APPLICATION ARE OUTSIDE OF HABASIT'S CONTROL, HABASIT DOES NOT ASSUME ANY LIABILITY CONCERNING THE SUITABILITY AND PROCESS ABILITY OF THE PRODUCTS, INCLUDING INDICATIONS ON PROCESS RESULTS AND OUTPUT.

