



Flexproof-Cutter AF-102



The Flexproof-Cutter AF-102 is a device for preparing (finger cutting) Habasit machine tapes up to a width of 100 mm/4 in. and a thickness of 2 mm/0.08 in. for Flexproof (finger) joints. It is suitable for the standard Habasit 8 x 30 mm finger geometry. The tape is positioned and securely clamped on an aluminum support. Fingers are then cut manually. The cutter is precisely positioned on the support with a pin matching a row of precisely cut indexing grooves; the angle is given by a guiding block fixed to the cutter.

The AF-102 is suitable for the occasional on-site preparation of Hamid tapes.



Table of contents:

1.	General information	3
1.1	Application.....	3
1.2	Important safety terms	3
1.3	Scope of supply.....	4
1.4	Ordering of accessories/spare parts.....	4
1.5	Warranty.....	4
1.6	Technical advice	4
2.	Mode of operation	5
3.	Initial start-up	5
4.	Cutting of belt/tape ends	6
5.	Service	7
5.1	Maintenance.....	7
6.	Illustrations	8
6.1	Cutting of first and second belt/tape end	8
6.2	Flexproof-Cutter with compensation belt piece.....	9
7.	Technical data	10
8.	Drawings	11

Appendix:

- Product Liability



1. General information

1.1 Application

The Flexproof-Cutter AF-102 was specifically designed for the rapid and safe preparation (die-cutting) of Habasit tapes and belts using the Flexproof procedure. The belts/tapes can be up to 100 mm/4.0 in. wide. The maximum thickness is 2 mm/0.08 in.

The Flexproof-Cutter AF-102 was developed solely for the purposes described in the operating instructions. Improper use, or use for other applications than those described in the instructions, is not permissible. Habasit accepts no liability for the consequences of improper application.

The Flexproof-Cutter AF-102 is manufactured according to recognized engineering principles and state-of-the-art technology, and complies with applicable regulations.

These operating instructions imply that all assembly, maintenance, and repair work, as well as operation of the die-cutting device, be carried out by skilled personnel or monitored by responsible specialists.

For reasons of scope, these instructions cannot cover all possible aspects of operation, maintenance, or repair. The indications given herein refer to the use of the tools according to their designated purpose by skilled personnel.

In case of doubt or if further detailed information is required, please contact the manufacturer (Section 1.4)

1.2 Important safety terms

In these operating instructions, you will find the terms WARNING, CAUTION, and INDICATION. They signal dangers or special information to be borne in mind.

WARNING If disregarded, there is a danger of severe injury, and/or severe material damage.

CAUTION If disregarded, there is a danger of injury, and/or material damage may be caused.

INDICATION Technical information is emphasized if it is important and not readily apparent, even for skilled personnel.

Please observe all indications for assembling, operating, and maintaining this device, as well as all technical data! This will prevent possible trouble and/or damage to people or materials.

Skilled personnel refers to persons authorized to perform the required work. These people have been sufficiently trained and introduced to their field of activity so that they are able to recognize and prevent dangers. They are aware of the pertinent provisions and safety regulations.



1.3 Scope of supply

Qty.	Item
1	AF-102 cutting support with cutting plate and clamping bar
1	Cutter with fixed guiding block
1	Table clamp
1	Operating instructions, all packed in a cardboard box

1.4 Ordering of accessories/spare parts

Spare parts and accessories can be ordered directly from the manufacturer.

Address:

Habasit Italiana S.p.A.
Via A. Meucci 8, Zona Industriale
I-31029 Vittorio Veneto/TV
Tel. ++39 438 91 13
Fax ++39 438 91 2374

Please accurately describe the parts required.
State the numbers according to Section 8, Drawings.

WARNING	The use of parts by other manufacturers not meeting Habasit specifications is not admissible. Habasit declines all responsibility for the consequences if non-Habasit parts are used.
----------------	--

1.5 Warranty

All tools undergo a strict final inspection. On the assumption of correct handling, they are warranted against material and manufacturing defects for 1 year.

1.6 Technical advice

Our specialists will be pleased to advise you. For technical questions concerning function and condition of the Flexproof-Cutter, please contact the manufacturer (Section 1.4).



2. Mode of operation

The fingers for the Flexproof joining method are manufactured at the belt ends by means of a special cutter with a single blade with individual cuts.

To achieve the required accuracy the cutter is precisely positioned on an aluminum support with a pin matching a row of precisely cut indexing grooves. The angle is given by a guiding block fixed to the cutter. The tape is positioned and securely clamped on the support by means of a clamping bar.

Fingers are cut manually step by step by a cutting operation performed by the cutter's single blade. The max. belt/tape thickness that can be cut is 2 mm/0.08 in. and 100 mm/4 in. is the max. possible belt/tape width.

3. Initial start-up

- Check the cutting blade for its cutting ability.
- Check to make sure that the surface of the cutting plate where the belts/tapes are to be cut is clean.
- For safe operation, place the Flexproof-Cutter AF-102 on a solid workbench or table.
- Attach the cutting support with the supplied table clamp.



4. Cutting of belt/tape ends

Process: Flexproof guidelines 32105 and individual product datasheets

- Measure belt/tape length and add 30 mm / 1.2 in. for the Flexproof fingers to its required length. Cut both belt/tape ends properly right angled.
- Open the clamping bar by loosening both knurled nuts and swinging the right side out.
- Insert the first belt/tape end from the back and first slide it against the stop on the left side. The cross-cut edge of the belt/tape has to be flush with the front edge of the cutting plate (see ill. 1).

INDICATION	For a clean cut and to prolong the life of the cutting blade and the cutting plate, insert a thin cardboard (approx. 0.2 mm/1/64 in. thick) between the cutting plate and the belt/tape.
------------	--

- Swing clamping bar back and tighten both knurled nuts.

INDICATION	To achieve proper clamping of small belts and to avoid shifting of the belt/tape end during cutting, insert a piece of belt/tape as height compensation (see ill. 3). The second belt/tape end can also be used for this purpose.
------------	---

- Engage cutter with its guide pin in the next notch to the right belt/tape edge and position its left shoulder against the cutting plate (see ill. 1). Make the first cut on the right by strongly pressing both handles together once.

INDICATION	To achieve properly cut fingers proceed always by cutting from the center towards the stops on the left and right side of the cutting plate. This provides more precise positioning of the belt/tape during cutting.
------------	--

- With the guide pin in the same notch, swing cutter around and position its right shoulder against the cutting plate and make the second cut on the left.
- Engage cutter with its guide pin in the next notch to the left. Make the cut on the right and the left as before.
- Repeat this procedure as many times as needed until the fingers are cut out across the entire belt/tape width.
- Now insert the other end of the belt/tape with the same side up as with the first belt/tape end. However, this time slide it against the stop on the right side.
- Engage cutter with its guide pin in the next notch to the left belt/tape edge and position its right shoulder against the cutting plate (see ill. 2). Make the first cut on the left.
- With the guide pin in the same notch, swing cutter around and position its left shoulder against the cutting plate and make the second cut on the right.
- Engage cutter with its guide pin in the next notch to the right. Make the cut on the left and the right as before.
- Repeat this procedure as many times as needed until the fingers are cut out across the entire belt/tape width.



5. Service

5.1 Maintenance

- Keep the cutting plate clean at all times. Clean it regularly and remove material residues.
- Check the cutting blade periodically for its cutting ability and replace it with the correct type if necessary.
- Slightly lubricate the hinge of the cutter with oil at periodic intervals.
- When not in use store the Flexproof-cutter AF-102 in its box.



6. Illustrations

6.1 Cutting of first and second belt/tape end

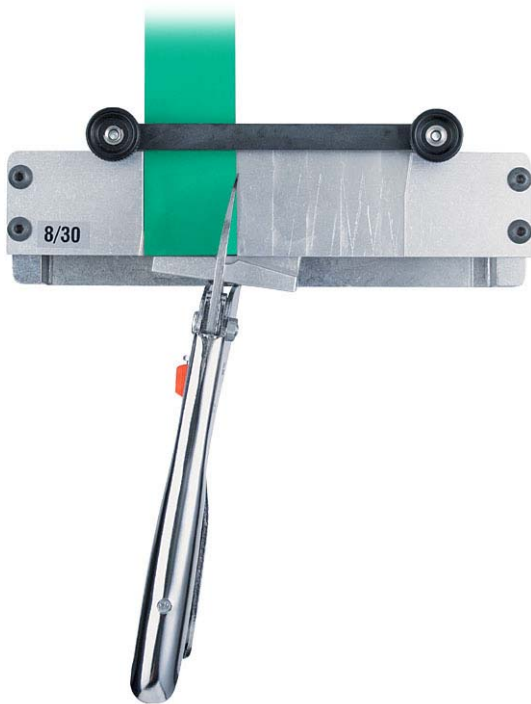

Illustration 1: Cutting of first belt/tape end

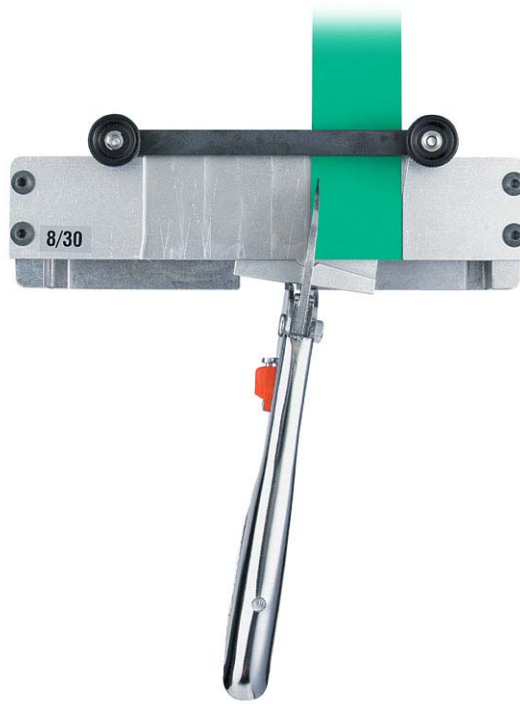

Illustration 2: Cutting of second belt/tape end



6.2 Flexproof-Cutter with compensation belt piece

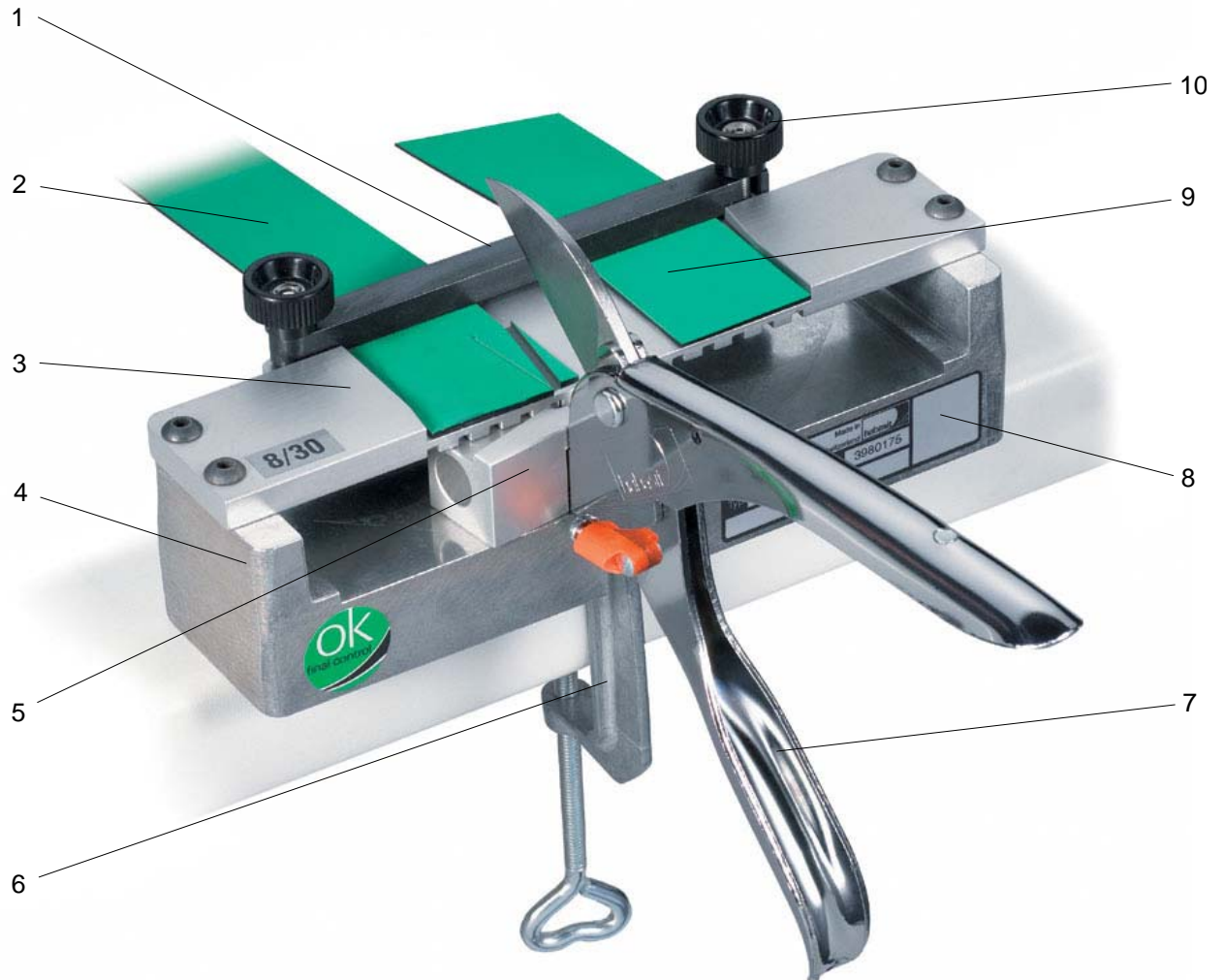

Illustration 3: Flexproof-Cutter with inserted compensation belt/tape piece

Legend:

- 1 Clamping bar
- 2 Belt/tape end to be cut
- 3 Cutting plate
- 4 Cutting support
- 5 Guiding block
- 6 Table clamp
- 7 Single blade cutter
- 8 Rating plate
- 9 Compensation belt/tape piece
- 10 Knurled nut



7. Technical data

Max. belt/tape width [mm] [<i>in.</i>]	100	4.0
Max. belt/tape thickness [mm] [<i>in.</i>]	2	0.08
Dimensions (L x W x H) [mm] [<i>in.</i>]	200 x 52 x 85	8 x 2 x 3.3
Net weight [kg] [<i>lbs.</i>]	1.6	3.5



8. Drawings

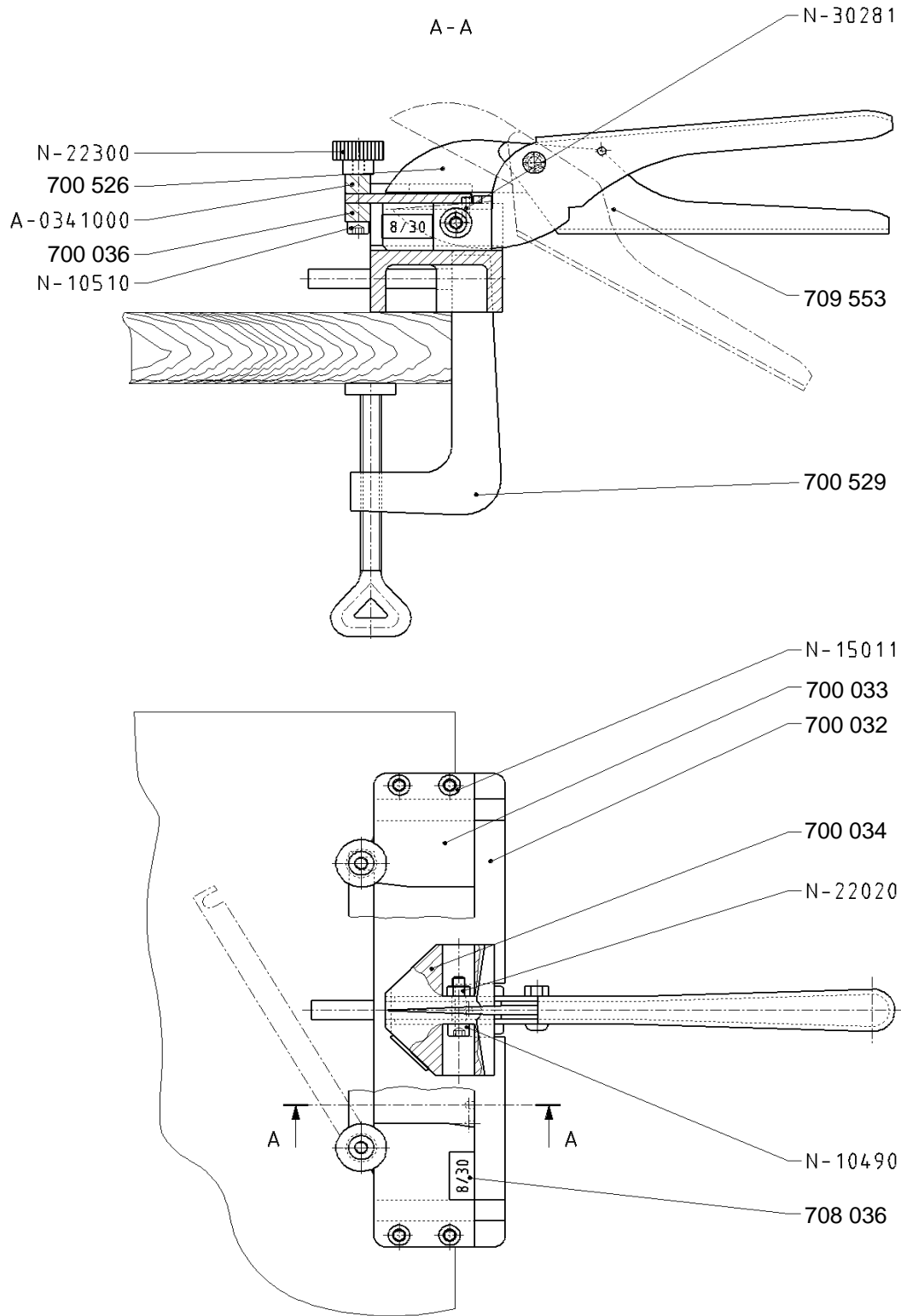



Product liability, application considerations

If the proper selection and application of Habasit products are not recommended by an authorized Habasit sales specialist, the selection and application of Habasit products, including the related area of product safety, are the responsibility of the customer.

All indications / information are recommendations and believed to be reliable, but no representations, guarantees, or warranties of any kind are made as to their accuracy or suitability for particular applications. The data provided herein are based on laboratory work with small-scale test equipment, running at standard conditions, and do not necessarily match product performance in industrial use. New knowledge and experiences can lead to modifications and changes within a short time without prior notice.

BECAUSE CONDITIONS OF USE ARE OUTSIDE OF HABASIT'S AND ITS AFFILIATED COMPANIES CONTROL, WE CANNOT ASSUME ANY LIABILITY CONCERNING THE SUITABILITY AND PROCESS ABILITY OF THE PRODUCTS MENTIONED HEREIN. THIS ALSO APPLIES TO PROCESS RESULTS / OUTPUT / MANUFACTURING GOODS AS WELL AS TO POSSIBLE DEFECTS, DAMAGES, CONSEQUENTIAL DAMAGES, AND FURTHER-REACHING CONSEQUENCES.
