

# SKIVING DEVICE

Type: AT-305

## GENERAL MANUAL USE AND MAINTENANCE

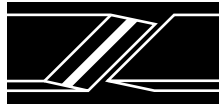


ORDER :

S.N.:

**Habasit Italiana S.p.A. - Via A. Meucci 8 Zona Industriale - I - 31029 Vittorio Veneto**

This document is the property of HABASIT ITALIANA and, therefore, must not be passed on to persons or Bodies outside the sphere of the Company unless previously authorized by the Technical Department for Industrial and Quality Systems.



## FOREWORD

### IMPORTANT

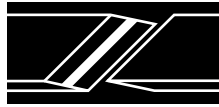
BEFORE INSTALLING, SETTING UP AND OPERATING THE SKIVING DEVICE, THE CUSTOMER MUST CAREFULLY READ THIS MANUAL AND CAREFULLY FOLLOW THE INSTRUCTIONS IT CONTAINS IN ORDER TO ENSURE THE SKIVING DEVICE IS USED SAFELY AND CORRECTLY. ALL OPERATORS AND/OR MAINTENANCE PERSONNEL MUST KNOW THIS MANUAL TO ENABLE THEM TO WORK SAFELY ON THE SKIVING DEVICE.



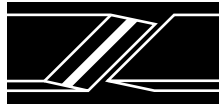


## SUMMARY

|           |  |            |
|-----------|--|------------|
| <b>A.</b> | <b>REGULATIONS AND GENERAL WARNING NOTES.....</b>      | <b>A-1</b> |
| A.1       | Reading assistance notes .....                         | A-2        |
| A.2       | How the manual is organized .....                      | A-3        |
| A.3       | Use criteria.....                                      | A-4        |
| A.4       | Guarantee conditions.....                              | A-5        |
| A.4.1     | Guarantee terms and validity.....                      | A-5        |
| A.4.2     | When the guarantee can be voided.....                  | A-5        |
| A.5       | Visual signs.....                                      | A-6        |
| A.5.1     | Signs.....   | A-6        |
| A.6       | Safety warnings .....                                  | A-9        |
| A.7       | Remaining risks .....                                  | A-10       |
| A.8       | Qualification of personnel .....                       | A-11       |
| A.9       | References and standards .....                         | A-12       |
| A.9.1     | Applicable EU Directives .....                         | A-12       |
| A.9.2     | EU Directives concerning safety in the workplace ..... | A-12       |
| A.9.3     | EU Directives concerning personal protection .....     | A-12       |
| A.9.4     | EU Directives concerning environmental protection..... | A-12       |
| <b>B.</b> | <b>TECHNICAL SPECIFICATIONS.....</b>                   | <b>B-1</b> |
| B.1       | Purpose of the skiving device .....                    | B-2        |
| B.2       | Identification data of the equipment.....              | B-3        |
| B.3       | Technical specifications.....                          | B-4        |
| B.4       | Equipment and accessories provided.....                | B-5        |
| B.4.1     | Base unit.....   | B-5        |
| B.4.2     | Control box .....                                      | B-5        |
| B.4.3     | Accessories provided.....                              | B-5        |
| B.4.4     | Consumables.....                                       | B-5        |
| B.5       | Ordering of accessories and spare parts.....           | B-6        |
| <b>C.</b> | <b>INSTALLATION .....</b>                              | <b>C-1</b> |
| C.1       | Preparation of working area .....                      | C-2        |
| C.2       | Packing and handling .....                             | C-3        |
| C.2.1     | Handling.....  | C-3        |
| C.3       | Assembling and installation .....                      | C-4        |
| C.3.1     | Preliminary check .....                                | C-4        |
| C.3.2     | Positioning .....                                      | C-4        |
| C.3.3     | Electrical connection.....                             | C-5        |
| C.4       | Equipment disassembly.....                             | C-6        |
| C.5       | Storage .....  | C-7        |
| C.6       | Disposal .....   | C-8        |



|           |   |            |
|-----------|---|------------|
| <b>D.</b> | <b>OPERATION .....</b>                              | <b>D-1</b> |
| D.1       | General warnings.....                               | D-2        |
| D.2       | Guards installed.....                               | D-3        |
| D.3       | Start up .....                                      | D-4        |
| D.3.1     | Calibration of the zero line.....                   | D-4        |
| D.3.2     | Setting up of the skiving angle.....                | D-4        |
| D.4       | Skiving of the belt/tape ends .....                 | D-5        |
| D.5       | Machine emergency stop .....                        | D-5        |
| D.6       | Technical assistance .....                          | D-6        |
| D.7       | Troubleshooting.....                                | D-6        |
| <b>E.</b> | <b>ORDINARY MAINTENANCE.....</b>                    | <b>E-1</b> |
| E.1       | General .....                                       | E-2        |
| E.2       | General warnings.....                               | E-3        |
| E.3       | Routine and scheduled maintenance .....             | E-4        |
| E.3.1     | Preliminary operations .....                        | E-4        |
| E.3.2     | Replacing of the skiving roller.....                | E-5        |
| E.3.3     | Replacing of the emery paper .....                  | E-5        |
| E.3.4     | Replacing of the transmission belt.....             | E-5        |
| E.3.5     | Replacing of the wear plate .....                   | E-6        |
| <b>F.</b> | <b>EXTRAORDINARY MAINTENANCE.....</b>               | <b>F-1</b> |
| F.1       | Extraordinary maintenance.....                      | F-2        |
| F.1.1     | Adjustments, replacements and synchronization ..... | F-2        |
| <b>G.</b> | <b>ILLUSTRATIONS.....</b>                           | <b>G-1</b> |
| G.1       | Overall views of AT-305.....                        | G-2        |
| G.2       | Control box versions .....                          | G-4        |
| G.3       | Detail views of AT-305.....                         | G-5        |

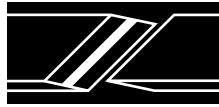


## SUMMARY OF THE FIGURES

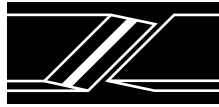
|   |     |
|---|-----|
| FIGURE 1 – MACHINE IDENTIFICATION PLATE.....        | B-3 |
| FIGURE 2 – OVERALL VIEW FROM THE LEFT .....         | G-2 |
| FIGURE 3 – OVERALL VIEW FROM THE RIGHT .....        | G-3 |
| FIGURE 4 – CONTROL BOX VERSIONS OF AT-305 .....     | G-4 |
| FIGURE 5 – DISASSEMBLING OF THE SKIVING ROLLER..... | G-5 |
| FIGURE 6 – THE TRANSMISSION BELT .....              | G-5 |
| FIGURE 7 – REPLACEMENT OF THE WEAR PLATE .....      | G-5 |

## SUMMARY OF TABLES

|  |      |
|--|------|
| TABLE 1 – DANGER SIGNS .....                                 | A-6  |
| TABLE 2 – TERMS AND DEFINITIONS .....                        | A-7  |
| TABLE 3 – QUALIFICATIONS .....                               | A-11 |
| TABLE 4 – ELECTRICAL CHARACTERISTICS.....                    | B-4  |
| TABLE 5 – DIMENSIONS AND ENVIRONMENTAL CHARACTERISTICS ..... | B-4  |
| TABLE 6 – CHARACTERISTICS OF WORKABLE ELEMENTS.....          | B-4  |
| TABLE 7 – ACCESSORIES PROVIDED.....                          | B-5  |
| TABLE 8 – CONSUMABLES .....                                  | B-5  |
| TABLE 9 – STORAGE CONDITIONS .....                           | C-7  |
| TABLE 10 – PERIODIC MAINTENANCE WORK.....                    | E-6  |



**A. REGULATIONS AND GENERAL WARNING NOTES**



## A.1 Reading assistance notes

Meanings of notes used in this manual:

### **ATTENTION**

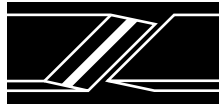
Note of particular interest for the safety of the people running and maintaining the skiving device.

### **WARNING**

Note of particular interest concerning the safety of the skiving device.

### **NOTE**

*A request for the reader's attention referred to the subsequent paragraph.*

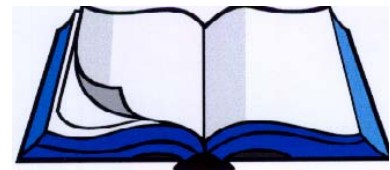


## **A.2 How the manual is organized**

This skiving device was designed, built and tested by expert technicians. The high quality materials used to build the skiving device make it operationally highly reliable.

For further, more detailed information or in regard to problems, please contact the following address:

**Habasis Italiana S.p.A.**  
**Via A. Meucci 8**  
**Zona Industriale**  
**I - 31029 Vittorio Veneto**  
**Tel.: 0039 (0) 438 9113**  
**Fax: 0039 (0) 438 200545**



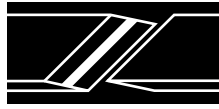
This manual observes the organizational rules and requirements of Directive 98/37/CE, duly amended, being the Directive of the Council of the European Community of June 14, 1989, concerning the reconciliation of the laws of member states regarding machines, also known as the «Machine Directive», and also all the other Directives and Regulations referred to in the said Machine Directive, inspired by criteria which, in addition to illustrating the technical characteristics of the machine and its use, maintenance and troubleshooting methods, also clearly indicate the following:

All the protection measures adopted on the skiving device, fully integrating design safety planning and construction safety.

All protection measures to be adopted to meet those risks that cannot be completely eliminated.

All indications for the training of personnel using the skiving device, while indicating where it is necessary to provide for individual safety protection devices.

The manual is divided up into sections. Each section deals with a specific subject in which every aspect of safety is considered and clearly highlighted in the text.



### **A.3 Use criteria**

HABASIT requests the Customer to fully read this manual on delivery of the skiving device it accompanies, and always before attempting any action on the skiving device. This manual is arranged to supply all the instructions, indications and warnings the user may need in order to know the skiving device, understand its operating principles, and to be adequately informed to ensure safe use.

In addition to the instructions in this manual, we would ask users to observe any specific current laws. This manual must be considered as an essential part of the machine. Its content must be made known to the entrusted maintenance persons and users. The purpose is to provide all the information required for good, correct use of the device.

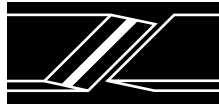
The manual must be kept throughout the life of the skiving device and must be updated in the event of modifications aimed at improving the device's performance. The manual must be available to qualified personnel.

Consultation of this manual is facilitated by the general index on the first page, which makes it possible to immediately find the subject of interest. If the subject dealt with is particularly important it is highlighted with references to the type of technical personnel required to intervene.

All updates HABASIT considers necessary to improve the quality of the skiving device will be communicated by way of sending further specific documentation or a new manual to replace the previous one.

If the skiving device is sold to another customer, the manual must accompany the skiving device and the new customer must be notified to HABASIT for any future modifications and updates.

A copy of this manual, delivered with the skiving device, is meant for the maintenance operators, who shall read and keep it near the skiving device, and consult it before undertaking any action on the skiving device.



## **A.4 Guarantee conditions**

### **A.4.1 Guarantee terms and validity**

The manufacturer guarantees the product against any faults either in materials or in workmanship, for 1 (one) year from the date of installation of the product at the Buyer's premises. In this case, the manufacturer shall limit itself to replacing or repairing any part or parts returned to the manufacturer, which was/were found to be faulty.

The manufacturer may, at his own discretion, also replace or repair any part or parts of the product being repaired that is/are felt to be defective.

The manufacturer shall have the sole right to decide if such parts should be repaired or replaced.

The manufacturer shall not be liable in any other case for collateral or incidental damage.

The guarantee does not apply to plant that has been repaired by third parties that have NOT been authorized by the manufacturer.

Spare parts supplied by the manufacturer must be used. Any deviation from this rule will mean the guarantee will not apply.

### **A.4.2 When the guarantee can be voided**

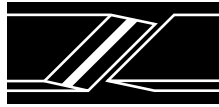
The manufacturer's guarantee for the plant and associated equipment may be annulled as a result of improper intervention or repairs.

The manufacturer's guarantee for the equipment may be annulled as a result of the use of improper materials or materials not supplied by the manufacturer.

This manual's instructions must be observed or the guarantee cover will be lost.

## **IMPORTANT**

HABASIT CANNOT BE HELD RESPONSIBLE FOR ANY DAMAGE CAUSED BY IMPROPER, INCORRECT AND UNREASONABLE USE OF THE SKIVING DEVICE.



## A.5 Visual signs



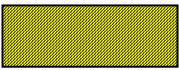
### ATTENTION

Visual signs – indicator notices – are applied to the skiving device. A knowledge of their meaning helps ensure that safety regulations are observed to prevent accidents and assure good operation. All people approaching the skiving device must have a clear understanding of the symbol and its meaning. Non observance may cause accidents entailing damage to personnel and to the skiving device.

### A.5.1 Signs

The signs affixed to the skiving device are shown below. Such signs enable staff operating or working on the skiving device to know about and so prevent the dangers and risks of not observing the principal safety rules.

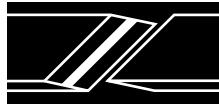
TABLE 1 – DANGER SIGNS

|   |   |
|---|---|
|  | <b>Attention: DANGER OF ELECTRIC SHOCKS</b><br>Indicates the personnel involved that, if the described operation is not performed while observing safety regulations, there is a risk of suffering an electric shock. |
|  | <b>Attention: DANGER OF CRUSHING OF OR INJURIES TO HANDS AND FINGERS</b><br>Indicates the presence of materials which can cause damage to limbs. Do not remove safety devices.  |
|  | <b>Attention: MOVING PLATE</b><br>Indicates the presence of moving material which could cause injuries.   |

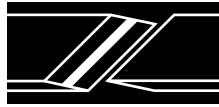


**TABLE 2 – TERMS AND DEFINITIONS**

| <b>TERM</b>                     | <b>DEFINITION</b>   |
|---------------------------------|---|
| <b>PROTECTION DEVICES</b>       | Safety measures involving the use of specific technical means called protection devices (guards, safety devices) to protect persons from dangers that cannot be reasonably eliminated or sufficiently reduced in the design of the machine.   |
| <b>GUARD</b>                    | A part of the machine specifically used to provide protection by the use of a physical barrier. Depending on how it is made, a guard may be called a cowling, cover, screen, door or fence etc.<br>Note 1 - A guard may act: - alone; in which case it is effective only when closed - associated with a locking device with or without locking the guard; in this case protection is assured whatever the position of the guard.<br>Note 2 - «Closed» means, in the case of a fixed guard, «kept in position». |
| <b>FIXED GUARD</b>              | Guard kept in position (i.e. closed), by means of a fastening (screws, bolts etc.) that make its removal/opening impossible without the use of tools.   |
| <b>MOBILE GUARD</b>             | Guard that is generally mechanically connected to the frame of the machine or to nearby fixed element (by means for example of hinges or guides), and that can be opened without the use of tools.  |
| <b>INTERLOCKED MOBILE GUARD</b> | Guard associated with an interlock device so that: The machine's dangerous functions «protected» by the guard cannot be carried out unless the guard has been closed<br>– If the guard is opened during the unfolding of the machine's dangerous functions, a stop command is given<br>– The closure of the guard permits execution of the machine's dangerous functions «protected» by the guard but it does not control the start up.   |



|                                      |   |
|--------------------------------------|---|
| <b>SAFETY DEVICE</b>                 | Eliminates or reduces the risk, either alone or in association with a guard.  |
| <b>INTERLOCK DEVICE (INTERBLOCK)</b> | A mechanical or electrical or other kind of device whose aim is to prevent elements of the machine from functioning under specified conditions (generally until the guard is closed).   |
| <b>PROTECTION STRUCTURE</b>          | A physical obstacle such as a guard or part of the machine that limits the movement of the body and/or one of its parts. The safety distances have been determined on the basis of the requisites at point 4.1.1 of the standard UNI EN294. |
| <b>SAFETY DISTANCE</b>               | The minimum distance a protective structure must be positioned with respect to a dangerous area. The safety distances have been determined on the basis of the requisites at point 4.1.1 of the standard UNI EN294.                         |
| <b>INDIVIDUAL PROTECTION DEVICE</b>  | Safety devices such as gloves, shoes, helmet, visor, earplugs etc. aimed at protecting parts of the body.   |
| <b>CONTROL CIRCUIT</b>               | A circuit used to control the working of the machine and protect the power circuits.  |
| <b>CONTROL DEVICE</b>                | A device inserted into a control circuit and used to control the working of the machine (e.g. position sensors, manual control switches, relays and electromagnetic valves).  |



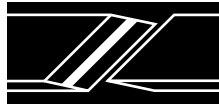
## A.6 Safety warnings

When using industrial machines and systems, one should be aware that moving mechanical parts (linear or rotary movement), high voltage electrical parts, and any parts at high temperature, etc, can cause serious damage to persons and materials.



In designing and building the skiving device, the Manufacturer focused special attention on safety in order to supply a SAFE skiving device and, therefore, the Manufacturer has provided protective and safety devices considered necessary according to the Risk Analysis carried out by expert personnel. People in charge of system safety must make sure that the following essential safety regulations are observed:

|            |   |
|------------|---|
|            | <p>Do not run the skiving device with the fixed and mobile protective devices dismantled or disabled.</p>   |
|            | <p>Do not run the skiving device with the fixed and mobile protective devices dismantled or disabled.<br/>             It is forbidden to switch off safety devices installed on the skiving device or create by-pass systems to limit switches or micro-switches.</p>  |
|            | <p>Operations with reduced safety devices must be carried out strictly observing the instructions in the relevant descriptions, and must be performed by specialized technicians aware of the risk, under the direct supervision of the company person responsible for safety. Active protective devices must be restored as soon as possible, limiting this high risk status to the minimum.</p> |
| <p>OFF</p> | <p>Cleaning and maintenance operations must be performed with the electrical and pneumatic cut-out devices switched OFF. To this end, the skiving device is provided with emergency push-buttons which shut down the system. It is good practice to use them as safety lock-outs to avoid accidental starting during inspections or mechanical jobs.</p>  |
|            | <p>Clean covers and control panel with soft, dry cloths lightly dampened in detergent; do not use solvents as they could damage the surfaces.</p>   |
|            | <p>Do not modify the skiving device or its parts. Otherwise, the Manufacturer shall not hold itself responsible for damage to persons and materials. Request any modifications/customizing directly from the Manufacturer.</p>  |



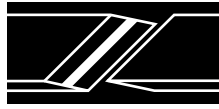
## **A.7 Remaining risks**

The use of the skiving device during its operation may give risk to additional risks such as the following:

The possibility of crushing occurring during bracket closing and table moving.

The user is responsible for taking care during transportation and movement of the equipment where the use of extraneous equipment (such as forklift trucks etc.) present dangers from bumping into and crushing persons in the area of these operations.




Ensure during equipping and maintenance operations that the stages in the chapters of the manual are scrupulously adhered to and have these operations carried out only by suitably prepared and qualified persons.

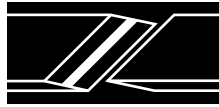


## A.8 Qualification of personnel

Each task must be assigned to a person trained in the work to be carried out and trained in correct usage as well as fully aware of any remaining risks and dangers in that work. Personnel must not carry out work outside their area of competence, knowledge and responsibility.

**TABLE 3 – QUALIFICATIONS**

|   |   |
|---|---|
|    | <p><b>FIRST LEVEL MACHINE CONTROL OPERATOR</b></p> <p>Indicates non qualified personnel i.e. without specific competencies and able only to carry out simple tasks, including in practice running the machine with the use of the controls on the push-button panel and loading and unloading materials used during production. Furthermore, this operator can work with the machine while the machine's protective devices are enabled, to carry out simple, ordinary jobs for adjusting, starting or re-starting production following enforced down-time.</p> |
|  | <p><b>MECHANICAL MAINTENANCE PERSON</b></p> <p>A qualified technician able to run the machine under normal conditions, to intervene on mechanical parts to make all adjustments as well as the necessary mechanical maintenance and repair jobs, also with the protective devices disabled.</p>   |
|  | <p><b>ELECTRICAL MAINTENANCE PERSON</b></p> <p>A qualified technician able to run the machine under normal conditions, and also with the protective devices disabled; s/he is entrusted with all electrical jobs involving adjustment, maintenance and repairs. This operator is able to work while the interior of the cabinets and the connector blocks are electrically live.</p>  |
|   | <p><b>QUALIFIED TECHNICIAN</b></p> <p>A person who is by training, experience, education and knowledge of accident prevention regulations and procedures able to perceive and avoid possible dangers and who is authorized by the plant's safety officer to carry out all necessary mechanical and electrical intervention.</p>   |
|   | <p><b>SPECIALIZED SUPERVISOR</b></p> <p>An expert, specialized technician provided by the Manufacturer to carry out complex operations in particular situations, installation, first start-up, instruction of the Customer's personnel, as well as overhauls of and modifications to the machine.</p>   |



## A.9 References and standards

### A.9.1 Applicable EU Directives

EU Directive N° 98/37 of 23.07.98 known as the "Machines directive".

EU Directive N° 60/204 known as "Low tension directive"

EU Directive N° 89/336 for the convergence of Member State law on electromagnetic compatibility.

**Application of the above directives is formalized through the signing of the MANUFACTURER'S DECLARATION OF CONFORMITY drawn up once the inspection test has been carried out at the place of installation.**

This skiving device has been constructed in a country that is part of the European Community and therefore meets the safety requirements of EU directive 98/37/CE, in force from July 23, 1998. This conformity is certified and the skiving device bears the CE mark of compliance (see figure).

### A.9.2 EU Directives concerning safety in the workplace

EU Directive N° 89/391 concerning the improvement of the safety and health of workers during work, in addition to the following particular directives EU N° 89/654 and N° 89/655.

EU Directives N° 77/576 and N° 79/640 concerning safety signs in the workplace.

### A.9.3 EU Directives concerning personal protection

EU Directive N° 89/656 and N° 89/686 concerning the use of personal protection devices.

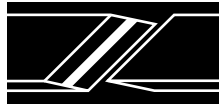
### A.9.4 EU Directives concerning environmental protection

EU Directives N° 75/442 on the disposal of waste.

EU Directives N° 78/319 on the disposal of toxic and harmful waste.



## **B. TECHNICAL SPECIFICATIONS**



## B.1 Purpose of the skiving device

The skiving device AT-305 has been specifically developed for joining of HABASIT power transmission and conveyor belts and machine tapes using the Thermofix process.

The AT-305 is a preparing device for skiving of belts and tapes up to a width of 300 mm and a thickness of 6 mm. The belt/tape is clamped and stuck on a steel table. This table is adjustable in tilt and is fed under a skiving roller on precise guides. The skiving roller is driven by a powerful three phase electric motor; feed is by means of a hand wheel. The result of this operation is a precise skiving, even on the most demanding belt/tape products.

The machine is operated manually: to operate it requires an operator, whose working position is in front of the machine.

The Thermofix process includes all the flat belts and other Habasis conveyor belts with right-angled or oblique-angled joints (for width and thickness details see: [TECHNICAL SPECIFICATION](#)).

Further details about the process can be obtained at:

For the **Thermofix** process (see technical manual Thermofix).

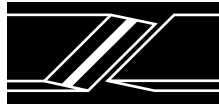
### NOTE

*By connecting to the company's IT net H/Net it is possible to access current valid process data.*

The skiving device AT-305 has been developed exclusively for the applications described herein. No other or inappropriate applications are permitted.

### ATTENTION

ANY USE OF THE SKIVING DEVICE OTHER THAN FOR WHICH IT WAS DESIGNED MAY BE IMPROPER USE AND RESULT IN NOT BEING SAFE FROM THE POINTS OF VIEW OF THE OPERATOR, MAINTENANCE WORKER AND OF THE SKIVING DEVICE ITSELF. HABASIT SHALL NOT BE HELD LIABLE FOR THE CONSEQUENCES OF ANY BREACHES OF THESE RULES.



## ATTENTION

THE USE OF THE MACHINE IN AREAS WITH DANGER OF EXPLOSION IS FORBIDDEN.

## IMPORTANT

All assembly, maintenance and repair work, as well as the operation of the equipment, is expected to be carried out by qualified personnel or staff under the supervision of responsible specialists and experts. In case of doubt or lack of detailed information, always contact the manufacturer (see [HOW THE MANUAL IS ORGANIZED](#)).

## B.2 Identification data of the equipment

A plate fitted to the structure of the skiving device indicates the device's identification data. These data are shown in the following figure.

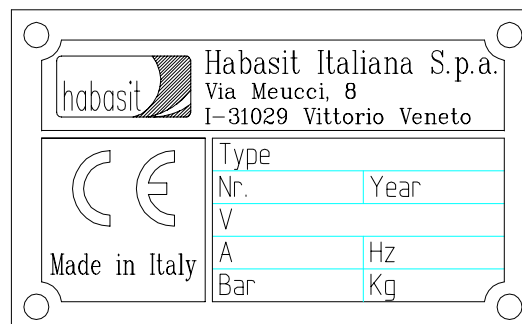
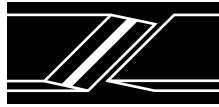


FIGURE 1 – MACHINE IDENTIFICATION PLATE



### B.3 Technical specifications

TABLE 4 – ELECTRICAL CHARACTERISTICS

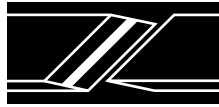
|           |  |
|-----------|--|
| Tension   | 3 x 400 V~<br>3 x 230 V~<br>1 x 230 V~ |
| Frequency | 50-60 Hz                               |
| Output    | 750 W                                  |

TABLE 5 – DIMENSIONS AND ENVIRONMENTAL CHARACTERISTICS

|                                      |   |
|--------------------------------------|---|
| Dimensions (length x width x height) | 650 x 800 x 500 mm<br><i>25.6 x 31.5 x 207 inch</i> |
| Total Weight                         | 110 kg / <i>242.5 lbs</i>                           |
| Noise level                          | <65 db(A)   |
| Working temperature                  | Between 15 °C – 38 °C                               |
| Humidity tolerance                   | Between 45 – 70%                                    |

TABLE 6 – CHARACTERISTICS OF WORKABLE ELEMENTS

|                            |                        |
|----------------------------|------------------------|
| Max width of belt/tape     | 300 mm / <i>12 in.</i> |
| Max thickness of belt/tape | 6 mm / <i>0.24 in.</i> |



## B.4 Equipment and accessories provided

The machine comprises the following parts:

- Skiving unit
- Control box

### B.4.1 Skiving unit

Standing on a steel frame [1] that holds the skiving table [2], wear plate [3], bracket [4] with the belt-clamping lever [5], advancement handwheel [6], three-phase motor [7], skiving roller [8], and suction nozzle [9].

### B.4.2 Control box

Formed by a container [20] to which are attached the start push button [21], stop push button [22], emergency push button [23], and reset push button [24].

### B.4.3 Accessories provided

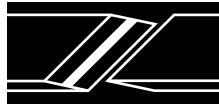
TABLE 7 – ACCESSORIES PROVIDED

| Quantity | Description                            | Code     |
|----------|--|----------|
| 1        | Wrench 14 mm                           | IN011356 |
| 1        | Hex-wrench 8 mm                        | IN060323 |
| 1        | Hex-wrench 6 mm                        | IN060322 |
| 2        | Emery paper P40 for the skiving roller | 031F1090 |
| 2        | Wear plate                             | 031B1170 |
| 2        | Double sided adhesive tape             | 031B1180 |

### B.4.4 Consumables

TABLE 8 – CONSUMABLES

| Quantity | Description                            | Code     |
|----------|--|----------|
|          | Emery paper P40 for the skiving roller | 031F1090 |
|          | Wear plate                             | 031B1170 |
|          | Double sided adhesive tape             | 031B1180 |
|          | Transmission belt                      | IN060288 |



## B.5 Ordering of accessories and spare parts

### IMPORTANT

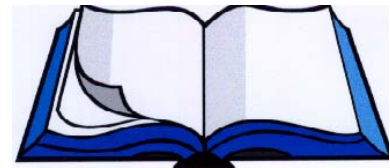
To order accessories or spare parts, please do the following:

- Quote the name of the skiving device.
- Quote the position of the part.
- Quote the description of the part.
- Quote the technical code.

When making your request, briefly illustrate the causes of failure of the part being ordered, and provide all information which may be useful for understanding the malfunction. This will make it possible to pinpoint any shortcomings or incorrect procedures which may have caused the damage.

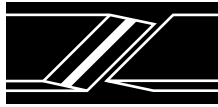
When ordering spare parts, we recommend using the fax and not just placing your order by phone.

**Habasit Italiana S.p.A.**  
**Via A. Meucci 8**  
**Zona Industriale**  
**I - 31029 Vittorio Veneto**  
**Tel.: 0039 (0) 438 9113**  
**Fax: 0039 (0) 438 200545**



The parts marked P and N are available at the headquarters of Habasit Reinach, Switzerland.

Habasis Italiana S.p.A.  
Vittorio Veneto 31029 (TV)  
Tel.: ++39(0)438.9113  
Fax. ++39(0)438.200545



**Skiving device AT-305**



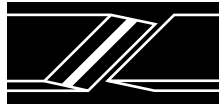
---

Author: S.D.T. / KM  
Edition: 02/2005  
Replaces: 01/2001

**INSTALLATION**  
Page **C-1**

---

## **C.           INSTALLATION**



## C.1 Preparation of working area

### ATTENTION

The skiving device must be placed on a floor or support of suitable size that is able to take the weight and bulk of the equipment.

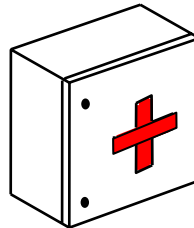
The machinery must be placed in a room with sufficient lighting, avoiding dazzling and stroboscopic effects. Personnel entrusted to control the skiving device must be able to work under normal light conditions (usually provided by neon lights fitted on the ceiling). If the lighting level is insufficient, the Customer must provide an additional lighting system since the machinery is not supplied with its own lighting system for the operational zone.

The work area must be well ventilated and/or have an air cycling and emission system compliant with the law of the country of installation, such as to ensure the operator is working under the proper working conditions.

The free space around the machine must be sufficient for work and maintenance operations and permit access all workstations taking account of the size of the pieces to be worked on.

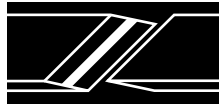
The Customer must provide all the sources of energy required as indicated in [TECHNICAL SPECIFICATIONS](#).

Ensure there is sufficient operational space around the skiving device.  
Make sure that there is a properly stocked first aid box on site nearby.



### ATTENTION

The main switch of the electrical panel must be in its «OFF» position when the skiving device is being connected up.



## C.2 Packing and handling

### ATTENTION

### C.2.1 Handling

The movement of the packaging and machinery should be carried out by authorized operators. Suitable equipment must be used to move the skiving device, with adequate strength to deal with the weight and bulk of the skiving device.

When unpacking, check that no small parts remain in the case, and carefully check the general conditions.

In transit, or on being moved, the skiving device must be disconnected.

Concerning disposal of packing materials, the user must observe the current laws of the country of installation.

### IMPORTANT

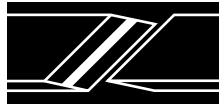
REPORT ANY DAMAGE NOTED ON THE SKIVING DEVICE AT DELIVERY TO THE CARRIER AND SUPPLIER.

Packing materials (wood, nails, plastic, barrier bags, etc.) can be sources of danger and should be placed in collection points, especially if polluted or non-biodegradable.

The user must observe the waste disposal legislation in the country of installation when disposing of the packaging.

### ATTENTION

ALL HANDLING OPERATIONS OF THE SKIVING DEVICE MUST BE PERFORMED SLOWLY WITHOUT ANY SUDDEN MOVEMENTS, TO AVOID DAMAGING PERSONS AND MATERIALS.



## **C.3 Assembling and installation**

### **C.3.1 Preliminary check**

Carry out a visual check on the device's appearance and on any accompanying equipment to see if there are signs of damage or breakage that may have occurred in transit. If such damage and/or failures are noted, contact HABASIT immediately. We advise you to also produce photographic evidence of the damage.

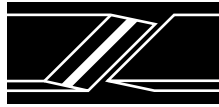
### **C.3.2 Positioning**

#### **IMPORTANT**

This operation requires the involvement of a **QUALIFIED TECHNICIAN** able to carry out and check correct positioning in observance of current safety regulations:

Make sure there is sufficient operational space for working on the machine.  
Position the equipment so that it is stable and at ergonomic height.  
Check visually to make sure that no rags, work tools, etc remain on the skiving device.

Fix the base unit [1] to a solid workbench, using the 4 flanges on the frame.  
Connect a suction sleeve to the suction nozzle [9].  
Fix the control box [20] securely to the workbench.



### C.3.3 Electrical connection

#### **ATTENTION**

Ensure all the plant providing the equipment corresponds with its own specifications.

Ensure the main switch is set at "OFF".

Connect the box [20] supply wire to the electricity supply panel. Connection must ensure continuity on the PE conductor to earth the machine.

#### **ATTENTION**

THE MACHINE MUST BE PROPERLY EARTHED TO GUARANTEE THE SAFETY OF PEOPLE.  
HABASIT WILL NOT BE HELD RESPONSIBLE FOR ANY DAMAGE DERIVING FROM POOR OR  
FAULTY EARTHING OF THE MACHINE.



## **C.4 Equipment disassembly**

Skiving device dismantling operations must be performed by:

Technicians of HABASIT Assistance Service.

Technicians authorized by HABASIT, with experience of: Machine assembly/disassembly, assembly/disassembly of the electrical, pneumatic and hydraulic plant, consulting the corresponding diagrams.

### **ATTENTION**

BEFORE CARRYING OUT ANY KIND OF WORK ON THE SKIVING DEVICE IT IS ESSENTIAL TO ENSURE THAT THE SYSTEMS ARE DISCONNECTED FROM ENERGY SUPPLIES AND THAT THERE IS NO REMAINING POTENTIAL ENERGY IN THE MOVING PARTS.

### **ATTENTION**

Follow the following disconnection procedure:

Disconnect the electrical circuit.

Carry out mechanical disassembly.

If the skiving device has to be stored for a certain time, prepare it as indicated in the next section, but if it has to be handled immediately, refer to the appropriate section.



## C.5 Storage

### IMPORTANT

The skiving device must be stored in a dry room free from seepage of liquids.

### NOTE

*Never, on any account, store the skiving device out of doors! As a general rule, observe the following environmental conditions.*

**TABLE 9 – STORAGE CONDITIONS**

|  | <b>Environmental conditions for storage</b> |
|--|---|
| Min/Max ambient temperature of storage | In the range of +5 °C to +40 °C             |
| Relative humidity of place of storage  | In the range of 50% to 70%                  |

If the skiving device, its accessories and spares have to remain in storage for a prolonged period, they must be protected from dust and damp.

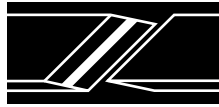
### **We recommend the following:**

Clean the skiving device in general.

Apply PROTECTIVE SILICONE OIL to **un**-painted or **un**-treated parts.

Cover the skiving device with a sheet to protect it from dust.

Before being oiled or greased for good preservation, some parts can, if necessary, be cleaned with a specific, rust-proofing detergent.



## C.6 Disposal

### **IMPORTANT**

The skiving device AT-305 is built with different types of material. When they have reached the end of their useful life, such materials must be disposed of at specialized centers, according to the prescriptions of the laws in force in the country of destination.

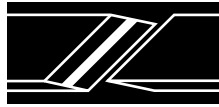
### **ATTENTION**

The materials and substances making up the skiving device **MUST** be eliminated according to the Laws/Regulations on disposal of individual waste in force in the country where the skiving device is installed.

IN ANY EVENT, NO COMPONENT OF THE SKIVING DEVICE MUST BE LEFT IN THE ENVIRONMENT.

CONTACT AN AUTHORIZED COMPANY TO CARRY OUT THIS TYPE OF OPERATION.

Habasis Italiana S.p.A.  
Vittorio Veneto 31029 (TV)  
Tel.: ++39(0)438.9113  
Fax. ++39(0)438.200545



**Skiving device AT-305**



---

Author: S.D.T. / KM  
Edition: 02/2005  
Replaces: 01/2001

**OPERATION**  
Page D-1

---

## **D. OPERATION**



## D.1 General warnings

The operator and/or the maintenance person have the following responsibilities:

To create on and around the skiving device the necessary conditions so that the installed protective devices are operational and efficient, as their purpose is to protect the personnel.

To observe the safety regulations described in the use and maintenance manual.

### **IMPORTANT**

THE INFORMATION DEVICES (SIGNS) AND SAFETY NOTICES MUST BE KEPT CLEAN AND LEGIBLE.

### **ATTENTION**

DO NOT IN ANY WAY ALTER THE SAFETY SYSTEM.

### **ATTENTION**

IT IS ABSOLUTELY FORBIDDEN TO REMOVE THE PROTECTIVE DEVICES INSTALLED.

### **ATTENTION**

CARRYING OUT CLEANING AND MAINTENANCE JOBS WHILE THE SYSTEMS ARE LIVE OR UNDER PRESSURE IS ABSOLUTELY FORBIDDEN.

### **ATTENTION**

DO NOT REMOVE THE GUARDS WHICH REQUIRE TOOLS FOR THEIR REMOVAL.



## D.2 Guards installed

The skiving device has the following protection devices:

### **Guards.**

The GUARDS are classified as:

### **Fixed guards.**

### **IMPORTANT**

The skiving device has been designed and built in conformity with European and IEC safety standards.

All the potentially harmful or dangerous parts have been rendered inaccessible to the operator. Guards, covers and safety devices have been installed for this purpose.

The production head must ensure that these protection devices are not removed.

### **ATTENTION**

READ THE ACCIDENT PREVENTION SIGNS WITH CARE, DO NOT COVER THEM FOR ANY REASON AND REPLACE THEM IMMEDIATELY IF THEY GET DAMAGED.



## D.3 Start up

Press the start **push button** [21]. Check that the running direction of the **skiving roller** [8] is as shown by the arrow on the safety cover. If not, invert the two phases on the power supply wire.

### D.3.1 Calibration of the zero line

This must be done:

- ⇒ after replacement of the **skiving roller** [8]
- ⇒ when the skiving of the belt/tape end is uneven

Use the 6 mm hex-wrench provided.

- Stop the machine: press the **stop push button** [22].
- Stick a paper tape onto the end of the **wear plate** [3].
- Fix the **wear plate** [3] to the **skiving table** [2] with adhesive tape.
- Slowly turn the **handwheel** [6] so that the edge of the **wear plate** [3] is exactly under the **skiving roller** [8] axis.
- Press the start **push button** [21].
- Adjust alignment of the edge of the **wear plate** [3] with the **skiving roller** [8] by turning the **alignment screws** [13] with the 6 mm hex-wrench until a slight metallic skiving noise is heard.
- Turn the **alignment screws** [13] until skiving is even all along the width of the wear plate.
- Turn the **handwheel** [6] in the opposite direction to take the **skiving table** [2] to the starting point.

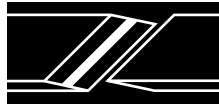
### D.3.2 Setting up of the skiving angle

To be carried out according to:

- ⇒ the thickness of the belt/tape (see individual joining data sheets)

Use the 8 mm hex-wrench provided.

- Stop the machine: press the **stop push button** [22.]
- Turn the **clamping screws** [11] anticlockwise.
- Turn the **regulating pivot** [12] to the value required (%) shown on the **scale** [14].
- Turn the **clamping screws** [11] clockwise and tighten.
- Carry out a skiving test and check the length of the skive. If necessary, adjust the position of the **regulating pivot** [12] repeating the operations described above until skiving is satisfying.



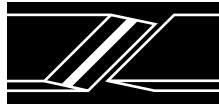
#### D.4 Skiving of the belt/tape ends

- Stop the machine: press the **stop push button** [22].
- Stick a strip of double-sided adhesive tape to the **wear plate** [3].
- Slide the belt/tape under the **belt-clamping bracket** [4], align the end of the belt/tape perfectly with the edge of the **wear plate** [3].
- Press the belt/tape by hand onto the adhesive tape to assure proper adhesion.
- Turn the **lever** [5] clockwise to clamp the belt/tape in place.
- Press the **start push button** [21].
- Turn the **handwheel** [6] slowly to advance the **skiving table** [2]: when skiving begins a loud noise is produced, which ceases when the skiving operation is finished.
- Turn the **handwheel** [6] in the opposite direction to check the skived end of the belt/tape.
- Repeat the skiving operation if necessary. If not, return the **skiving table** [2] to its initial position.
- Turn the **lever** [5] anticlockwise to release the belt/tape.
- Remove the belt/tape from the **wear plate** [3].
- Clean the skiving dust from **wear plate** [3] and **skiving table** [2].
- Repeat the procedure on the other belt/tape end on the opposite side.

#### D.5 Machine emergency stop

The machine can be stopped at any time by pressing the **EMERGENCY** push button [23] situated on the **control box** [20]. In this case all the machine controls are cut off.

When the cause of the emergency has been eliminated, release the **EMERGENCY** push button [23] by twisting and pulling its knob.



## D.6 Technical assistance

Our experts will be available for you to consult on the use of the skiving device. If you have any technical queries regarding the operation and the status of the skiving device, contact the manufacturer (see address in [HOW THE MANUAL IS ORGANIZED](#))

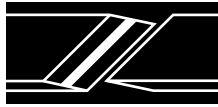
## D.7 Troubleshooting

### **ATTENTION**

Maintenance, repairs and replacement operations for electrical components must be carried out by an ELECTRICAL MAINTENANCE TECHNICIAN or a QUALIFIED TECHNICIAN able to perform the tasks in accordance with safety regulations.



## **E. ORDINARY MAINTENANCE**

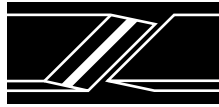


## **E.1            General**

### **ATTENTION**

IT IS ESSENTIAL TO CARRY OUT PREVENTIVE MAINTENANCE OF THE SKIVING DEVICE TO PROTECT THE RELIABILITY OVER TIME OF ITS COMPONENTS AND PARTICULARLY ITS MOVING PARTS.

HARMFUL AGENTS SUCH AS DUST, ENCRUSTATION AND LIQUID SEDIMENTS CAN DAMAGE THE DEVICE'S COMPONENTS.



## **E.2 General warnings**

The operator and/or the maintenance person have the following responsibilities:

To create on and around the skiving device the conditions so that the installed protective guards and devices are operationally effective, as they are there for the purpose of protecting personnel.  
To observe the safety regulations described in the use and maintenance manual.

### **IMPORTANT**

THE INFORMATION DEVICES (SIGNS) AND SAFETY NOTICES MUST BE KEPT CLEAN AND LEGIBLE.

### **ATTENTION**

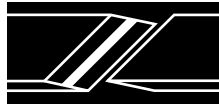
DO NOT IN ANY WAY ALTER THE SAFETY SYSTEM.

IT IS ABSOLUTELY FORBIDDEN TO REMOVE THE PROTECTIVE DEVICES INSTALLED.

CARRYING OUT CLEANING AND MAINTENANCE JOBS WHILE THE SYSTEMS ARE LIVE OR UNDER PRESSURE IS ABSOLUTELY FORBIDDEN.

DO NOT REMOVE THE GUARDS WHICH REQUIRE TOOLS FOR THEIR REMOVAL.

DO NOT WEAR CLOTHES WITH WIDE SLEEVES.



## **E.3 Routine and scheduled maintenance**

### **IMPORTANT**

Maintenance personnel must have knowledge of at least the following points:

- How the skiving device is protected.
- Mechanical and electrical safety devices.
- Precautions to observe during maintenance, including how to work under safe conditions.
- Equipment and clothes to be worn to reduce the risks of accidents.
- Maintenance personnel must be authorized and must not wear watches and finger-rings.

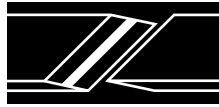
### **E.3.1 Preliminary operations**

#### **ATTENTION**

MAKE SURE THAT THE ELECTRICAL EQUIPMENT AND THE SYSTEM ARE NOT LIVE.  
CHECK IF OTHER SOURCES OF ENERGY ARE DISABLED TOO; I.E., AIR FEEDING.

#### **ATTENTION**

BEFORE CARRYING OUT ANY KIND OF WORK ON THE SKIVING DEVICE IT IS ESSENTIAL TO ENSURE THAT THE SYSTEMS ARE DISCONNECTED FROM ENERGY SUPPLIES AND THAT THERE IS NO REMAINING POTENTIAL ENERGY IN THE MOVING PARTS.



### E.3.2 Replacing of the skiving roller

- Stop the machine: press the **stop push button** [22].
- Loosen the three **knurled screws** [15] pull the **handle** [16] and remove the **cover** [17].
- Remove the worn **skiving roller** [8].
- Carefully fit the new roller into its seat.
- Fit the cover with the ball bearing onto the new roller.
- Push the **cover** [17] precisely down, aligning the three screw holes.
- Re-mount the **knurled screws** [15] and tighten completely.

### E.3.3 Replacing of the emery paper

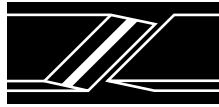
- Stop the machine: press the **stop push button** [22].
- Remove the **skiving roller** [8] according the procedure described above.
- Detach the worn emery paper.
- Clean the roller surface with an appropriate solvent (e.g. trichloroethylene).
- Stick the new emery paper onto the roller and press tightly onto the surface to prevent the formation of air bubbles.
- Re-assemble the **skiving roller** [8].

### E.3.4 Replacing of the transmission belt

- Stop the machine: press the **stop push button** [22].
- Loosen the screws on the **safety cover** [19] and remove the cover.
- Remove the worn **transmission belt** [26].
- Slip the new **belt** [26] onto the **motor pulley** [28] and the **skiving roller pulley** [27].
- Close the **safety cover** [19] and tighten the screws.

#### NOTE

The belt length is correct and no tensioning is required nor any regulation needed.

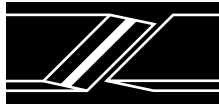


### E.3.5 Replacing of the wear plate

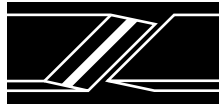
- Stop the machine: press the **stop push button** [22].
- Place the tip of a screwdriver in the **slots** [18] and lever out the worn **wear plate** [3].
- Remove the remainders of the adhesive tape and clean the surface with solvent.
- Stick double sided adhesive tape onto a new wear plate.
- Place the new plate in position, align carefully and press firmly down to make sure the surface is perfectly even.

TABLE 10 – PERIODIC MAINTENANCE WORK

| Operation                   | Period  | Personnel          | Method  |
|-----------------------------|---------|--------------------|---|
| General cleaning            | Daily   | Operator           | Clean the machine after each use.<br>Remove residual dust with a suitable suction device. |
| Lubrication                 | Monthly | Maintenance worker | Lubricate the handwheel screw with a thin film of grease. Wipe off any excess.            |
| Check off electrical cables | Monthly | Maintenance worker | Check for defective insulation or connectors.   |



## **F. EXTRAORDINARY MAINTENANCE**



## F.1 Extraordinary maintenance

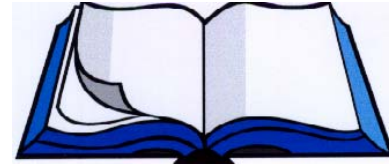
### F.1.1 Adjustments, replacements and synchronization

#### **IMPORTANT**

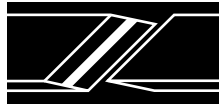
All routine and extraordinary maintenance jobs must be done with the skiving device switched OFF. Take special care with replacements and adjustments.  
Maintenance jobs must be done by qualified technicians.

FOR ANY MAINTENANCE WORK THAT DOES NOT COME WITHIN THE CATEGORY OF ORDINARY MAINTENANCE WORK, CONTACT THE TECHNICAL ASSISTANCE OFFICE OF HABASIT.

**Habasis Italiana S.p.A.**  
**Via A. Meucci 8**  
**Zona Industriale**  
**I - 31029 Vittorio Veneto**  
**Tel.: 0039 (0) 438 9113**  
**Fax: 0039 (0) 438 200545**



Habasis Italiana S.p.A.  
Vittorio Veneto 31029 (TV)  
Tel.: ++39(0)438.9113  
Fax. ++39(0)438.200545



**Skiving device AT-305**



---

Author: S.D.T. / KM  
Edition: 02/2005  
Replaces: 01/2001

**ILLUSTRATIONS**  
Page **G-1**

## **G. ILLUSTRATIONS**



## G.1 Overall views of AT-305

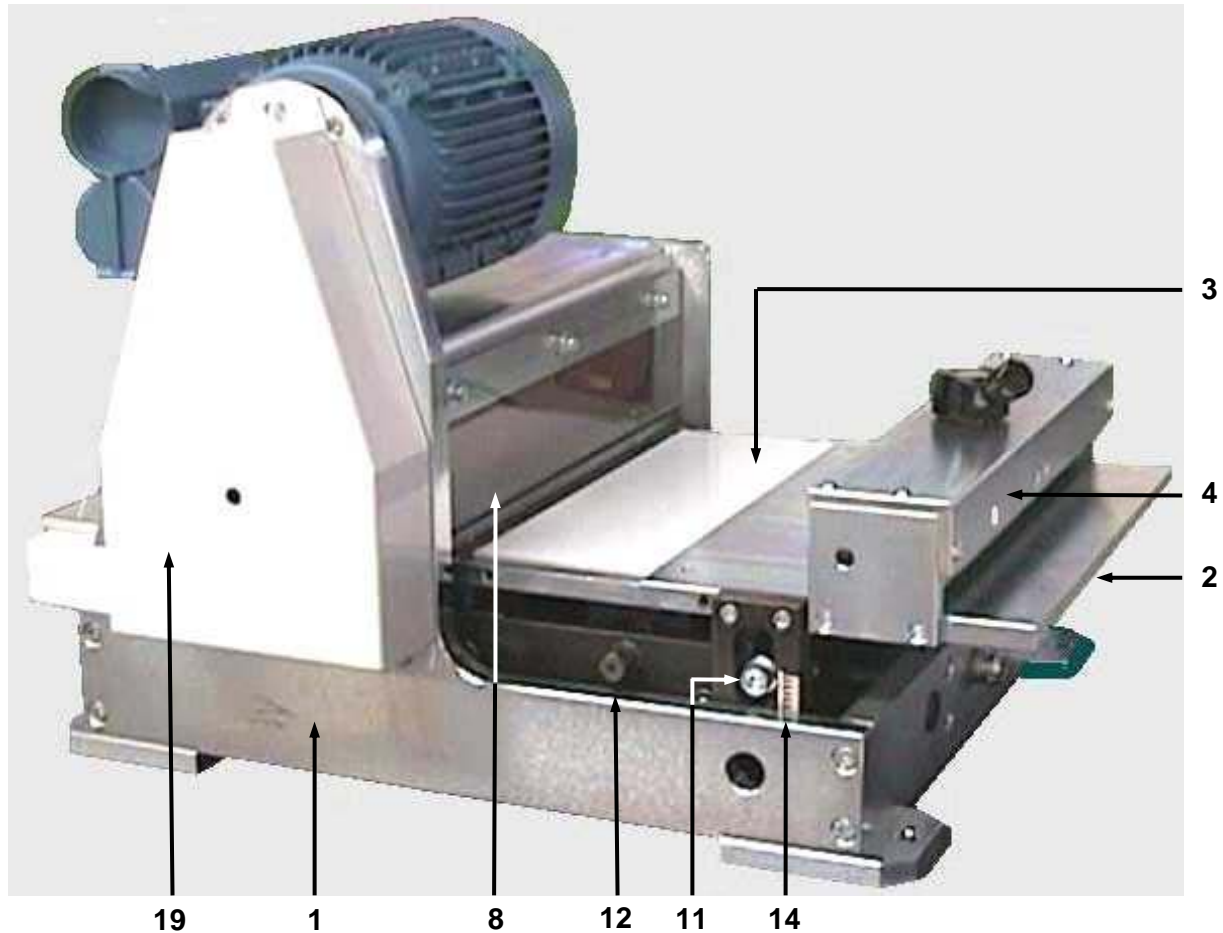


FIGURE 2 – OVERALL VIEW FROM THE LEFT

### Legend:

- |                       |                                   |
|-----------------------|-----------------------------------|
| 1 Basic frame         | 11 Lateral clamping screw         |
| 2 Skiving table       | 12 Skiving angle regulation pivot |
| 3 Wear plate          | 13 Wear plate alignment screws    |
| 4 Bracket             | 14 Scale                          |
| 5 Belt clamping lever | 15 Knurled screws                 |
| 6 Handwheel           | 16 Handle                         |
| 7 Motor               | 17 Cover                          |
| 8 Skiving roller      | 18 Slot                           |
| 9 Suction nozzle      | 19 Transmission belt cover        |

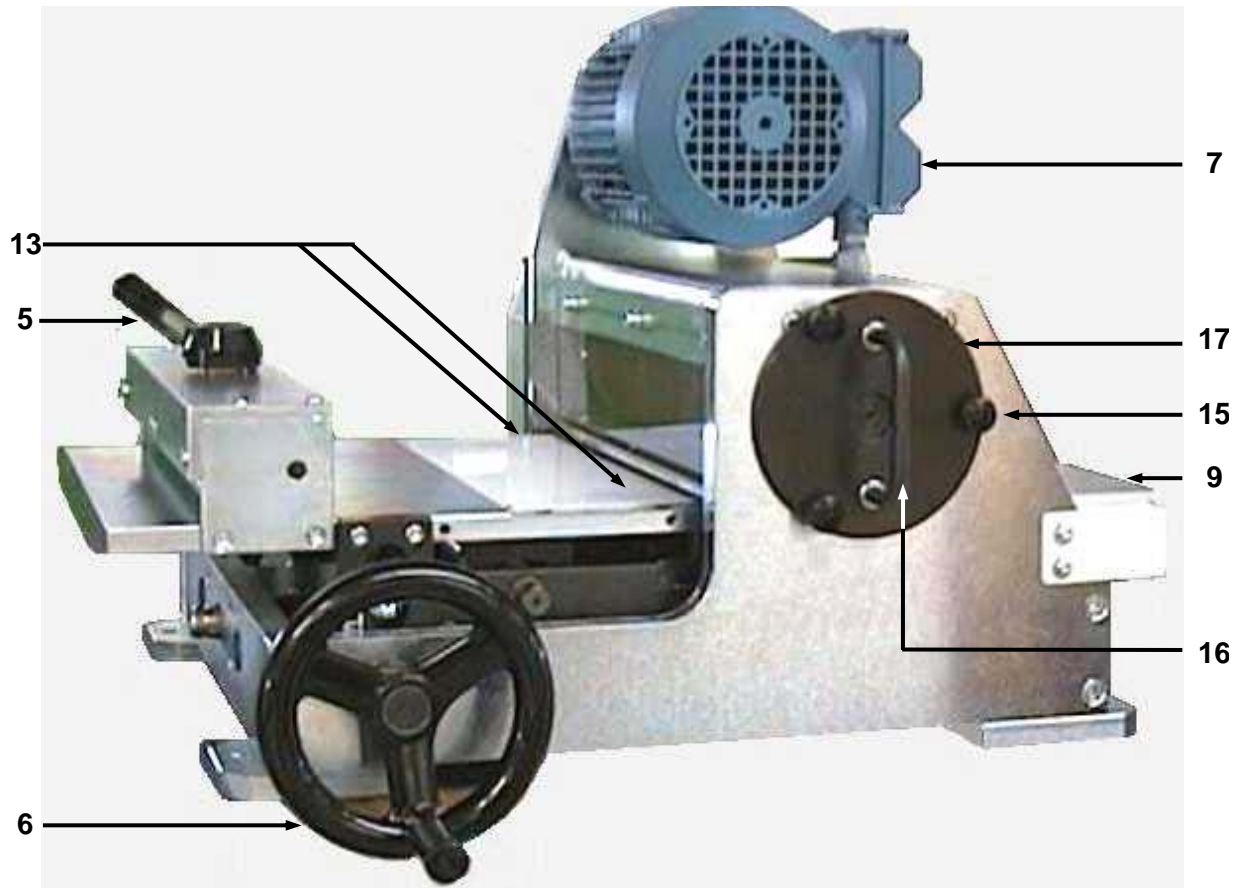
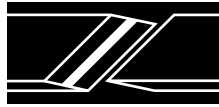
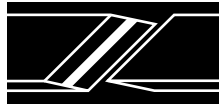


FIGURE 3 – OVERALL VIEW FROM THE RIGHT

**Legend:**

- |                       |                                   |
|-----------------------|-----------------------------------|
| 1 Basic frame         | 11 Lateral clamping screw         |
| 2 Skiving table       | 12 Skiving angle regulation pivot |
| 3 Wear plate          | 13 Wear plate alignment screws    |
| 4 Bracket             | 14 Scale                          |
| 5 Belt clamping lever | 15 Knurled screws                 |
| 6 Handwheel           | 16 Handle                         |
| 7 Motor               | 17 Cover                          |
| 8 Skiving roller      | 18 Slot                           |
| 9 Suction nozzle      | 19 Transmission belt cover        |



## G.2 Control box versions

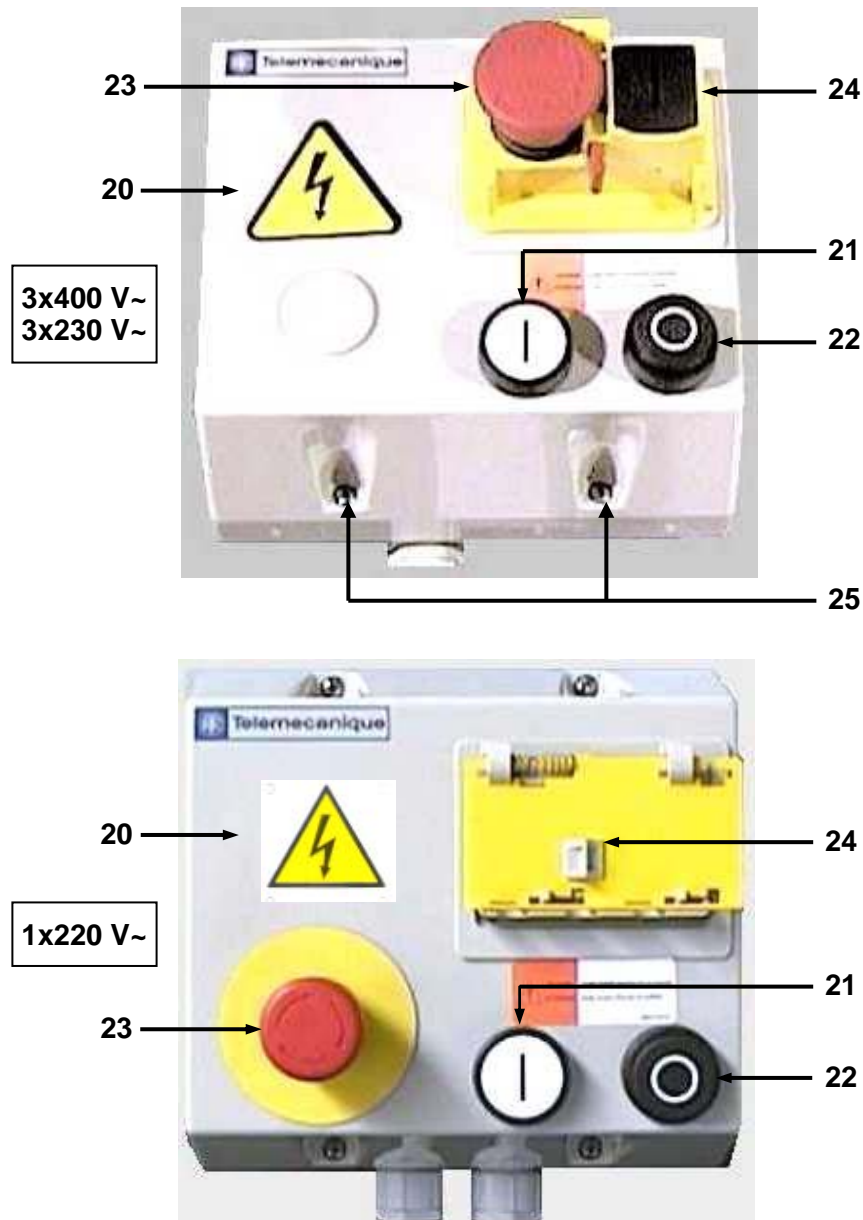
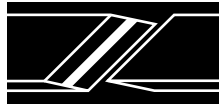


FIGURE 4 – CONTROL BOX VERSIONS OF AT-305

**Legend:**

- |                      |                               |
|----------------------|-------------------------------|
| 20 Control box       | 23 Emergency push button      |
| 21 Start push button | 24 Overload reset push button |
| 22 Stop push button  | 25 Fixing holes               |



### G.3 Detail views of AT-305

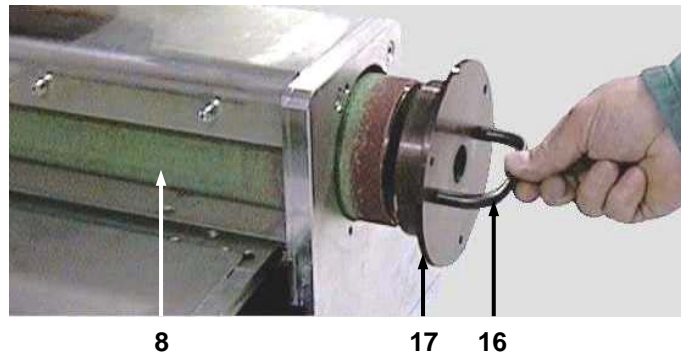


FIGURE 5 – DISASSEMBLING OF THE SKIVING ROLLER

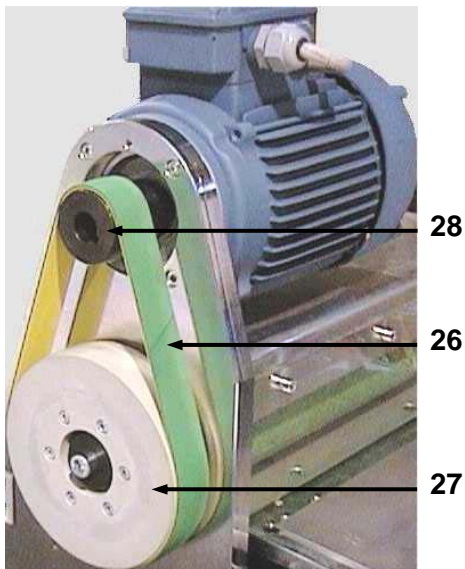


FIGURE 6 – THE TRANSMISSION BELT

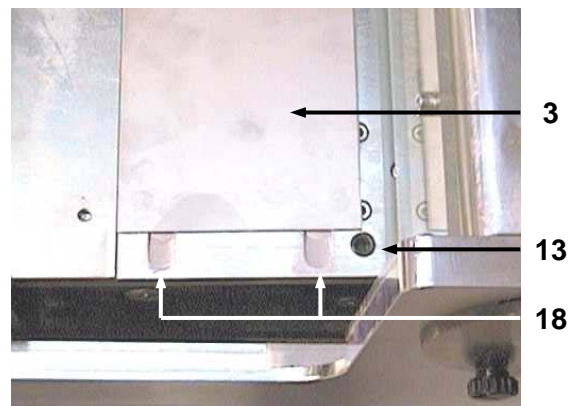
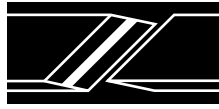


FIGURE 7 – REPLACEMENT OF THE WEAR PLATE

**Legend:**

- 3 Wear plate
- 8 Skiving roller
- 13 Alignment screw
- 16 Handle
- 17 Cover

- 18 Slot
- 26 Transmission belt
- 27 Skiving roller pulley
- 28 Motor pulley



---

### Product liability, application considerations

If the proper selection and application of Habasis products are not recommended by an authorized Habasis sales specialist, the selection and application of Habasis products, including the related area of product safety, are the responsibility of the customer.

All indications / information are recommendations and believed to be reliable, but no representations, guarantees, or warranties of any kind are made as to their accuracy or suitability for particular applications. The data provided herein are based on laboratory work with small-scale test equipment, running at standard conditions, and do not necessarily match product performance in industrial use. New knowledge and experiences can lead to modifications and changes within a short time without prior notice.

BECAUSE CONDITIONS OF USE ARE OUTSIDE OF HABASIT'S AND ITS AFFILIATED COMPANIES CONTROL, WE CANNOT ASSUME ANY LIABILITY CONCERNING THE SUITABILITY AND PROCESS ABILITY OF THE PRODUCTS MENTIONED HEREIN. THIS ALSO APPLIES TO PROCESS RESULTS / OUTPUT / MANUFACTURING GOODS AS WELL AS TO POSSIBLE DEFECTS, DAMAGES, CONSEQUENTIAL DAMAGES, AND FURTHER-REACHING CONSEQUENCES.

---