

Habasit® Cleandrive friction drive belts

CD.M00.B-UA.CB.30



Main industry segments

Dairy (incl. cheese), Fruit, Poultry, Red meat, Vegetables

Special features

Abrasion resistant, Abrasion resistant on both sides, Easy cleanability

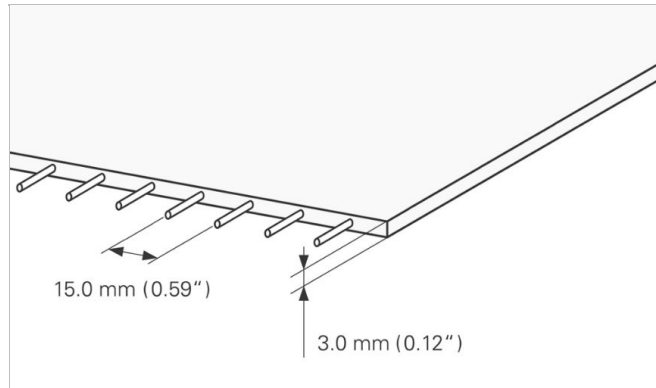
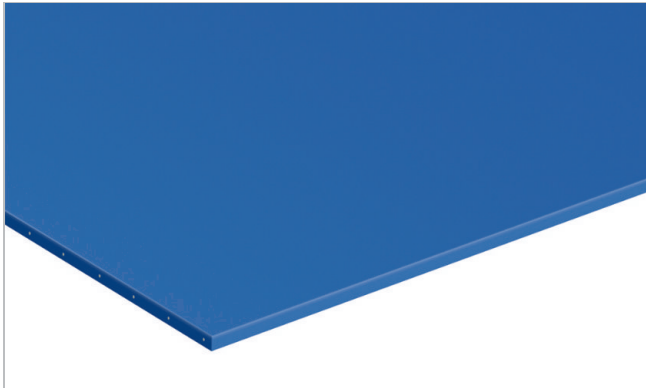

Product Construction / Design	
Material	Thermoplastic polyurethane (TPU)
Color	Cobalt blue
Conveying side surface	Glossy
Conveying side property	Adhesive
Traction layer (material)	Aramid cords
Pulley side surface	Glossy
Pulley side property	Adhesive

Product characteristics	
Antistatically equipped	No
Conveying side conductive surface acc. EN ISO	No
Slider bed suitable	Yes
Carrying rollers suitable	Yes
UV-C suitable	No
Laser markable	No
Flammability	No specific flammability prevention property
Food suitability, EU conformance	Yes - acc. to Regulation (EC) No. 1935/2004 as well as Regulation (EU) No. 10/2011 and/or other relevant food contact legislation. Details/restrictions see Habasit food compliance declaration.
Food suitability, FDA conformance	Yes - Check Document of Compliance (DoC) in our Portal
Food suitability, USDA recommendations	USDA certified for compliance with USDA Dairy Equipment Guidelines and NSF/ANSI/3-A 14159-3 standard for Meat and Poultry Processing. Certification is valid only if belt edges are sealed or belt cords are not exposed and when optional belt accessories like cleats, v-guides and scoops comply with the applicable FDA regulations for the conveyed product. Contact your Habasit representative for detailed information.
Other conformance/approval	Japanese Food Regulation (MHLW Notification No. 370)

Technical data			
Hardness	95	ShA	
Thickness of belt	3.0	mm	0.12 inch
Distance between cords	15	mm	0.59 inch
Mass of belt (belt weight)	3.5	kg/m ²	0.717 lb/sqft
Tensile force for 1% elongation (k1% static) per unit of width (Habasit standard SOP3-155)	9.5	N/mm	54 lbf/in
Tensile force for 1% elongation after relaxation (k1% relaxed) per unit of width (Habasit Standard SOP3-155 / EN ISO 21181)	7.0	N/mm	40 lbf/in
Min. operating temperature admissible (continuous)	-20	°C	-4 °F
Max. operating temperature admissible (continuous)	80	°C	176 °F
Coefficient of friction (pulley side / PE wearstrips)	0.50	-	
Coefficient of friction (pulley side / stainless steel slider bed)	0.80	-	
Coefficient of friction (conveying side / PE wearstrips)	0.50	-	
Minimal width of belt	150	mm	6 inch
Seamless manufacturing width	1810	mm	71.26 inch

Joining related properties

Joining method	
Quickmelt	Master joining method for standard applications

[Link to JDS:](#)

Joining method		Quickmelt
Pulley diameter (minimum)	mm inch	30 1.18
Pulley diameter minimum with counter flection	mm inch	30 1.18
Admissible tensile force per unit of width	N/mm lbf/in	8.0 46
Troughed installation suitable		Yes
X-Ray / Metal detectable material		No
X-Ray / Metal detector suitable		Yes

All data are approximate values under standard climatic conditions: 23°C/73°F, 50% relative humidity (DIN 50005/ISO 554). Limited representative testing based on a standard configuration is carried out to estimate minimum pulley diameters. Please contact Habasit for specific guidance regarding non-standard applications, including, but not exclusively, when profiles or cleats are used, or if the belt working temperature is close to the limits listed in this document.

Chemical resistance

Link to 'Chemical resistance information': <https://rims.habasit.com>

Calculations

For most applications calculation is not required. Should you still need a calculation: please ask Habasit.

Recommendation

Install the slack belt and tension until running perfectly under the full belt load, Do not go below initial elongation (epsilon) ~ 0.1%

Protect belts from sunlight/UV-radiation/dust and dirt. Store spare belts in a cool and dry place and if possible in their original packaging. Check Link for Storage requirements:

["https://tdm.habasit.com/pds/en-us/Storage%20of%20Habasit%20material.pdf"](https://tdm.habasit.com/pds/en-us/Storage%20of%20Habasit%20material.pdf)

This product has not been tested according to ATEX standards (atmospheres with explosion risk - ATEX 95 regulation or EU directive 2014/34/EU) and therefore is subject to user's analysis in the respective environment

Habasit® Cleandrive friction drive belts

CD.M00.B-UA.CB.30



Group	Habasit Cleandrive Friction Drive
Sub-Group	Habasit® Cleandrive Belt Series Smooth
Item number	H800004960

Disclaimer

Product Application Disclaimer (valid for ALL Habasit products and mentioned on all PDS)

This disclaimer is made by and on behalf of Habasit and its affiliated companies, directors, employees, agents and contractors (hereinafter collectively "HABASIT") with respect to the products referred to herein (the "Products"). SAFETY WARNINGS SHOULD BE READ CAREFULLY AND ANY RECOMMENDED SAFETY PRECAUTIONS BE FOLLOWED STRICTLY! Please refer to the Safety Warnings herein, in the Habasit catalogue as well as installation and operating manuals. All indications / information as to the application, use and performance of the Products are recommendations provided with due diligence and care, but no representations or warranties of any kind are made as to their completeness, accuracy or suitability for a particular purpose. The data provided herein are based on laboratory application with small-scale test equipment, running at standard conditions, and do not necessarily match product performance in industrial use. New knowledge and experience may lead to re-assessments and modifications within a short period of time and without prior notice.

EXCEPT AS EXPLICITLY WARRANTED BY HABASIT, WHICH WARRANTIES ARE EXCLUSIVE AND IN LIEU OF ALL OTHER WARRANTIES, EXPRESS OR IMPLIED, THE PRODUCTS ARE PROVIDED "AS IS". HABASIT DISCLAIMS ALL OTHER WARRANTIES, EITHER EXPRESS OR IMPLIED, INCLUDING, BUT NOT LIMITED TO, IMPLIED WARRANTIES OF MERCHANTABILITY, FITNESS FOR A PARTICULAR PURPOSE, NON-INFRINGEMENT, OR ARISING FROM A COURSE OF DEALING, USAGE, OR TRADE PRACTICE, ALL OF WHICH ARE HEREBY EXCLUDED TO THE EXTENT ALLOWED BY APPLICABLE LAW. BECAUSE CONDITIONS OF USE IN INDUSTRIAL APPLICATION ARE OUTSIDE OF HABASIT'S CONTROL, HABASIT DOES NOT ASSUME ANY LIABILITY CONCERNING THE SUITABILITY AND PROCESS ABILITY OF THE PRODUCTS, INCLUDING INDICATIONS ON PROCESS RESULTS AND OUTPUT.