

# HabasitLINK® sprockets – 3/4" pitch belting

## 106 FT, 106 10, 106 22, 106 RT, 106 V

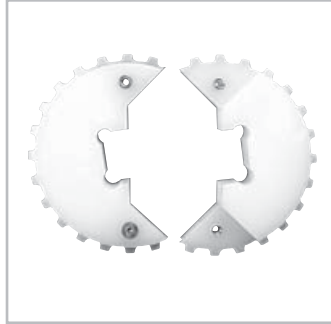

Machined sprocket



Machined split sprocket

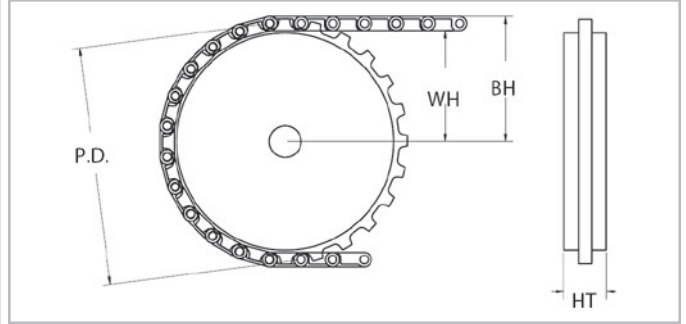

Sprocket part number	Number of teeth	(PD) Nominal pitch diameter		(WH) Shaft center to top of wearstrip		(BH) Shaft center to top of belt		(HT) Hub thickness	
		inch	mm	inch	mm	inch	mm	inch	mm
SB106PEU7	7	1.73	44	0.7	18	1.03	26	1.0	25
SB106PEU10	10	2.43	62	1.05	27	1.38	35	1.0	25
SB106PEU14	14	3.37	86	1.52	39	1.85	47	1.0	25
SB106PEU16	16	3.84	98	1.75	44	2.08	53	1.0	25
SB106PEU24	24	5.75	146	2.71	69	3.04	77	1.0	25
STB106PEU24	24	5.75	146	2.71	69	3.04	77	1.0	25
SB106PEU25	25	5.98	152	2.82	72	3.15	80	1.0	25
STB106PEU25	25	5.98	152	2.82	72	3.15	80	1.0	25

SB = solid body, STB = split body

Split sprockets and other tooth sizes are available. Standard machined sprocket material is UHMW, Nylon and Urethane are available.

Sprocket part number	Available bore size														
	20 mm	3/4"	25 mm	25 mm sq.	1"	1" sq.	30 mm	1-1/4"	1-7/16"	1-1/2"	1-1/2" sq.	40 mm	40 mm sq.	2" sq.	2-1/2" sq.
SB106PEU7	✓	✓	-	-	-	-	-	-	-	-	-	-	-	-	-
SB106PEU10	✓	✓	✓	✓	✓	✓	✓	✓	-	-	-	-	-	-	-
SB106PEU14	✓	✓	✓	✓	✓	✓	✓	✓	✓	✓	✓	✓	✓	-	-
SB106PEU16	✓	✓	✓	✓	✓	✓	✓	✓	✓	✓	✓	✓	✓	✓	✓
SB106PEU24	✓	✓	✓	✓	✓	✓	✓	✓	✓	✓	✓	✓	✓	✓	✓
STB106PEU24	✓	✓	✓	✓	✓	✓	✓	✓	✓	✓	✓	✓	✓	-	-
SB106PEU25	✓	✓	✓	✓	✓	✓	✓	✓	✓	✓	✓	✓	✓	✓	✓
STB106PEU25	✓	✓	✓	✓	✓	✓	✓	✓	✓	✓	✓	✓	✓	-	-

SB = solid body, STB = split body

All bore sizes are round bore unless designated square (sq.).